

6-4-2015

Feasibility study of an alternative approach to recycle shipping containers

Tofiq Mammadov
Illinois State University, tmammadov.tm@gmail.com

Follow this and additional works at: <https://ir.library.illinoisstate.edu/etd>



Part of the [Business Administration, Management, and Operations Commons](#)

Recommended Citation

Mammadov, Tofiq, "Feasibility study of an alternative approach to recycle shipping containers" (2015).
Theses and Dissertations. 433.
<https://ir.library.illinoisstate.edu/etd/433>

This Thesis is brought to you for free and open access by ISU ReD: Research and eData. It has been accepted for inclusion in Theses and Dissertations by an authorized administrator of ISU ReD: Research and eData. For more information, please contact ISUREd@ilstu.edu.

FEASIBILITY STUDY OF AN ALTERNATIVE
APPROACH TO RECYCLE SHIPPING
CONTAINERS

Tofiq Mammadov

118 Pages

August 2015

In this research, the author proposes to study the feasibility of applying ISO shipping containers as alternative construction materials. Using retired shipping containers for dwellings, offices or other construction purposes is an environmentally friendly idea. The “green generation” constitutes a battle against harmful effects of industrial developments. Motivated by the green movement, this research addressed the recycling of shipping containers in the construction market. Particularly, this research studied the recycling of shipping containers for the purpose of student housing construction.

The design and justification of the implementation of the innovative construction materials was achieved through the application of Building Information Modeling (BIM) systems. The research contribution includes the analysis of the feasibility of the application of the alternative structural components. This research discussed the development of an alternative sustainable method of construction. The author studied if the application of shipping containers as a structural component of a building can significantly reduce construction cost in addition to the decrease of

energy consumption. The author found that it is feasible to use shipping containers to develop midrise student residences with 4-7 stories living quarters.

FEASIBILITY STUDY OF AN ALTERNATIVE
APPROACH TO RECYCLE SHIPPING
CONTAINERS

TOFIG MAMMADOV

A Thesis Submitted in Partial
Fulfillment of the Requirements
for the Degree of

MASTER OF SCIENCE

Department of Technology

ILLINOIS STATE UNIVERSITY

2015

© 2015 Tofiq Mammadov

FEASIBILITY STUDY OF AN ALTERNATIVE
APPROACH TO RECYCLE SHIPPING
CONTAINERS

TOFIG MAMMADOV

COMMITTEE MEMBERS:

Haiyan Xie, Chair

Klaus Schmidt

Pranshoo Solanki

ACKNOWLEDGMENTS

It was an honor for me to work on the research, through which I learned so much about construction and the technology of Building Information Modeling. I was inspired and motivated to keep working on the research by the Lord, my God, who never left me. His presence and support was noticeable throughout the years of my study. To Him, I am most thankful.

I want to express special thankfulness to the Chair of my thesis committee, Dr. Haiyan Xie. It is even hard to appreciate enough for all the efforts she invested in this research. God bless her heart. I also want to appreciate Dr. Klaus Schmidt for his timely and wise recommendations and his support during the time of this research. I am grateful for Dr. Pranshoo Solanki, who supported me while developing the structural design for the research.

I thank the managerial personnel of Young America Realty, Inc. and Crosswalk Project, Inc., who so generously provided me with the information regarding the properties they manage. I am thankful to Bob Lukowski, the rental coordinator at Great Lakes Kwik Space, who agreed to conduct a phone interview with me regarding the prices of retired shipping containers.

Finally, I want to write a few sentences about dedication of the current research. In this day and age it is crucial to help American students to understand that there are other than using alcohol and prohibited drugs ways to spend their leisure time. A lot of

times lack of life experience limits college students to foresee future consequences of their actions. Therefore this thesis is mainly dedicated to motivate property developers who deal with student housing to care not only about their profits, but also about college students by providing them with an option to live in a place where their social and spiritual values can be developed and strengthened.

T. M.

CONTENTS

	Page
ACKNOWLEDGMENTS	i
CONTENTS	iii
TABLES	vi
FIGURES	viii
CHAPTERS	
I. INTRODUCTION	1
Problem Statement	1
Proposed Alternative Approach	3
Research Question and Significance	5
Quantification of the Project	7
II. LITERATURE REVIEW	9
Student Residence Types	9
Sustainable Architecture	11
Building Information Modeling	13
Thermal Properties of Materials	15
Energy Consumption and Parametric Simulations	16
Return Evaluation	18
Simple Payback Method	18
Time Value of Money	19
Discounted Payback Method	19
Shipping Containers' Structural Integrity	19
III. METHODOLOGY	22
Materials, Tools, Software and Data	22

Application of Autodesk Revit Architecture	22
Simulation Process	24
Economic Analyses of the Residence	24
Data	25
Research Limitation	27
Chapter Summary	27
IV. RESEARCH DESIGN	29
Case Study	29
Residence Design Methodology	34
Design and Modifications	34
Insulation	39
The HVAC, Plumbing, Electrical and Fire Sprinkling	
System Design	42
Connections	44
Structural Design	46
Building Foundation and Load Bearing Model	52
Gym, Fellowship Hall, and Studying Rooms Design	57
Model for Economic Analysis	59
V. DATA, ANALYSIS AND CONCLUSION	62
Budget Estimates	62
Energy Consumption Estimates	67
Construction and Energy Data Analysis	70
Financial Data	72
Economic Analysis	73
Recommendations for Future Research and Conclusion	76
REFERENCES	78
APPENDIX A: Justification of the Student Housing With Community Fellowship	
Elements	82
APPENDIX B: Interviews	84
APPENDIX C: Case Studies	90
APPENDIX D: Residence Budget Estimate	96
APPENDIX E: Financial Analysis	112

APPENDIX F: Distributions of NPV Generated Through Monte Carlo Simulation	116
APPENDIX G: Construction and Insulation Materials R Value	118

TABLES

Table		Page
1.	National Center for Education Statistics, Number of Admissions	7
2.	Comparison of Container's Components Durability against General Wind Loading Requirements	21
3.	Adjusted Construction Cost of Analyzed Properties	31
4.	General Information about Analyzed Properties and Their Analytical Coefficients	32
5.	Specification of Dimensions and Weights of Shipping Containers	34
6.	Insulation Requirements for Zone#5	39
7.	Insulated Wall Assembly's R Value	41
8.	R Value of The Roof that is above Shipping Containers	42
9.	R Value of The Roof that is not above Shipping Containers	42
10.	Dead and Life Load Table	55
11.	Load Applied per Load Bearing Components	56
12.	Assumptions for Economic Analysis	59
13.	Derivation of Monthly Rental Price per Bed	60
14.	Other Components of Economic Analysis	61
15.	Complete Budget Estimate of the Student Residence	66
16.	Case Studies' Energy Simulation Results	67

Table		Page
17.	Energy Simulation Results of Covington Apartments	69
18.	Alternative Student Residence Energy Simulation Results	70
19.	Comparison Analysis of General Data of Alternative Residence	71
20.	Derivation of Monthly Rental Price per Bed with Alternative Student Residence Included	72
21.	Monte Carlo Simulation Results #1	75
22.	Sensitivity Analysis for Associated Increase in Return of Investments	75
23.	Monte Carlo Simulation Results #2	76

FIGURES

Figure		Page
1.	20' ISO Shipping Container's Elements	20
2.	Apartment Layout (Plan View)	36
3.	Apartment Layout (Perspective View)	37
4.	First Modified 40' Shipping Container	37
5.	Second Modified 20' Shipping Containers	37
6.	Third Modified 40' Shipping Container	38
7.	Apartment's Conventional Flooring for Bathroom Area	39
8.	Insulated Wall (Plan View)	41
9.	Ceiling Drop in a Hall (Cut View)	43
10.	Apartment Ductwork	43
11.	Plumbing System	44
12.	Containers Stacked on Connection Device	45
13.	Double Ended Twist Lock	45
14.	Double Ended Twist Lock Dimensions	46
15.	Residence (Plan and Elevation Views)	47
16.	Structural Framing (Plan View)	47
17.	Structural Framing (3D view, 2 nd , 3 rd , and 4 th levels)	48

Figure		Page
18.	Recreational Area Floor Design	48
19.	Fellowship Hall, Floor Framing (Plan View, Level 4)	49
20.	Fellowship Hall, Floor Framing (3D View, Level 4)	49
21.	Elevator Shaft Design	50
22.	Stairwell Concrete Structure	50
23.	Stairwell Design	50
24.	Wood Framing on Structural Concrete as a Roof Support	51
25.	Roof above Fellowship Hall Design	51
26.	Roof above Shipping Containers Design	52
27.	Foundation Design (Plan View)	53
28.	Foundation Design (3D View)	53
29.	Recreational Area (Plan View)	57
30.	Fellowship Hall (Render)	57
31.	Fellowship Hall (Plan View)	58
32.	Studying Rooms (Plan View)	58
33.	Studying Rooms (Render)	59
34.	3D View of the Residence with Siding	65
35.	The Lodge on Willow Energy Model	69
36.	Covington Apartments Energy Model	69
37.	Crosswalk Commons Energy Model	70
38.	Normally Distributed Inflation	73

CHAPTER I

INTRODUCTION

Problem Statement

The United States of America is one of the top education providers in the world (Ranking Web of Universities, 2014, January). Student housing has developed for almost four centuries since approximately 1650. Today, education it is a multi-billion dollar business in the United States. Drummer (2013) stated in his report that investors and developers spent millions of dollars on student housing or dormitory buildings. Housing characteristics and options affect consumer choices. For example, the characteristics of student housing include the number of bedrooms or bathrooms of a house, the age of the building, or the distance from the building to the campus. College students and their parents consider all the features of the options and select the ones that fit their needs.

In this research, an off-campus area of Illinois State University (ISU) is considered for detailed analysis. ISU is located at the town of Normal in Illinois. According to the demographics of 2014, the total population of the town was 52,497 (US Census, 2015). In 2014, the total student population in ISU was 19,924 (ISU, 2015), which was 37.95% of the town's total population. Hence, student housing in Normal, IL, is one of the essential parts of local realty business.

After the development for many decades, the town hardly has any vacant space for new projects. From the real estate perspective, a similar situation can be observed around many other college campuses in the United States. For that reason, property owners invest millions of dollars in reconstruction and remodeling of the existing units of student housing.

Many of the investors of the student housing projects are interested in making changes to the inside of the buildings. Although the properties will appear new and attractive from the inside, their exterior appearances would still be old or even weathered. Many student-housing properties still don't have centralized and efficient cooling and heating systems. The properties may need the perimeter wiring for Internet to go all-around the buildings, .It is hard to balance the need to increase the amount of bathrooms and the requirement to maintain the other useful areas in those apartments. The decision of reducing the size of one area to improve the function of another may cause challenges. Though there are a lot of constraints regarding the aforementioned investments, property owners still do not want to demolish their old (but still profitable) buildings and build modern, efficient, and environmental-friendly buildings. Newly-constructed student-housing usually has a significantly higher rental price than that of an old building. The associated risk for the owners of the properties is that they may have difficulties leasing their new projects. Therefore, property owners often prefer to just keep maintaining their old buildings.

In Normal, Illinois, large realty businesses that are dealing with student housing, such as First Site and The Flats, are trying to conquer the commercial areas that are relatively close to campuses for their new multimillion-dollar projects. For example

in 2014, First Site Company completed the new Uptown North project near the ISU campus; the Flats Company completed their third student-apartment building at 709 South Main Street. Both projects were approximately 5 minutes walking distance from campus. The main reason that those companies were able to develop those new projects is that they were able to tolerate the relatively small margins. Compared to the average monthly rental payments around ISU campus, which are \$400-\$450 for old construction (Realtor.com, n.d.), the minimum charge of Uptown North is \$709 per month (First Site, n.d.). The substantial difference in price is the main reason that property owners do not want to start new construction, but keep updating the existing ones instead. This research suggests examining the alternative construction methodologies against the traditional ones for the purpose of encouraging new, comfortable, affordable, and environmentally-friendly buildings. The research has possibly the social impact in helping college students to reduce their financial burden. Many students undertake huge loan debts for higher education. After graduation, many are struggling to pay off their student loans, which significantly affects their lives. That also causes a lot of stress after graduation. Sometimes people may need to spend 10 or more years to clear off their student-loan debts. However, if housing expenses were reduced, it would reduce the pressure of paying back loans.

Proposed Alternative Approach

Herr (2011) estimated that over 17 million shipping containers are scattered all around the world (Herr, 2011). However, due to the economic instability of recent decades, there is a surplus on the shipping container market. There are around 1 million containers sitting unused (HL Design Group, 2010). Although the main purpose of using

shipping containers is the transportation of goods, containers are found to be useful in many other ways.

The main benefits of steel shipping-containers are their durability and the ability to be modified for numerous uses. Containers are made to endure extreme loads and heavy wear and tear (Zuiderwyk, 2014). Built from weathering steel, containers can resist harsh environments, such as weather or salt corrosion etc. (HL Design Group, 2010).

The use of retired containers in affordable construction is growing exponentially for the following reasons: (1) it seems to be cheaper to build houses using containers; (2) the durability and strength of containers make them an ideal structural component of a building; (3) containers are made according to standard measurements, which simplifies design, planning, delivery, and assembly; (4) due to its simplicity in construction, container buildings can be finished up to 40% faster comparing to traditional construction (HL Design Group, 2010); (5) because of its structural strength, containers are ideal for multi-story dwellings.

Giriunas, Sezen, and Dupaix (2012) provided research about the structural integrity of both modified and non-modified containers. Their research offered information about the structural strength of containers and mentioned that shipping-container buildings can be economical, durable, and fast to.

Although it seems to be a brilliant idea to use shipping containers in construction, a lot of developers prefer not to deal with them for the following concerns: A building made out of shipping containers requires special insulation due to thermal conductivity of steel. It's rough-in works for heating and cooling system, plumbing and

electrical, and in some cases sprinkling systems can take a lot of efforts. The rough-in work requires steel-cutting which is very expensive. Design flexibility is another issue. The building design is restricted to the cubic shape of containers. In some cases floors of shipping containers treated with harmful chemicals that need to be removed.

Research Question and Significance

The question of current research is whether shipping containers could be used to replace the traditional structural components and construction materials for student housing projects.

Without proper insulation, the high thermal conductivity of steel can result in raised energy cost of a building. This can significantly increase utility expenses, which in turn increases the life-cycle cost of the residence. The production of steel material is also energy intensive. An enormous amount of energy is required by the metallurgical industry (Sultanguzin, Isaev, & Kurzanov, 2010). Steel is a very common material that is used for making structural components of a building. Based on the amount of CO₂ that is formed due to annual steel production, the industry generates 5-25 million tons of greenhouse gases (Sultanguzin, Isaev, & Kurzanov, 2010). The energy consumption is more crucial now than ever and will be even more important as energy sources continue to be exhausted by the worlds' dependence on resources of energy suppliers (Estes, 2011).

The application of shipping containers as a structural component of a building can reduce the market's demand for structural steel and therefore reduce the amount of environmental pollution. Another significant aspect of the research is the potential to satisfy student housing demand. Table 1 shows that based on the data provided by the

National Center for Education Statistics (n.d.), on average, the universities in the US admit 164,872 more students each year. The 20th Annual Residence Hall Construction Report showed that median price of Construction Cost per Resident in 2008 is \$35,124 (Argon, 2008). Therefore, the student-housing industry potentially requires \$5.8 billion annual investment into new construction. A reduction of the Cost/Resident ratio by 1% will save \$58 million in investments. In addition, the research significance is also reflected in the fact that current research will equip housing developers with valid methodologies to evaluate alternative construction materials. The third significant aspect of this research is that concepts of sustainability can be integrated in prefabricated construction without harming the affordability of it.

In summary, if the usage of shipping containers as a structural component of a building does not increase energy consumption and results in a reduction of construction costs and faster project delivery, the adoption of the methodology and design can benefit society in three main directions: (1) reduction of environmental pollution through reduction of demand on structural steel; (2) property owners can be motivated to start new construction with higher density dwelling to help to meet student housing demand; (3) reduction of unutilized shipping containers.

Table 1. *National Center for Education Statistics, Number of Admissions.*

Year	Number of Admissions	Growth Rate
2002	3,017,870	
2003	3,172,478	5.12%
2004	3,276,922	3.29%
2005	3,418,336	4.32%
2006	3,571,114	4.47%
2007	3,734,199	4.57%
2008	3,934,730	5.37%
2009	4,178,895	6.21%
2010	4,295,306	2.79%
2011	4,407,954	2.62%
2012	4,575,888	3.81%
2013	4,776,460	4.38%
Average	3,863,346	4.27%
Average Annual Increase*	164,872	
Note: Average Annual Increase is Average Number of admissions multiplied by Average Growth rate.		

Quantification of the Project

Developers pay close attention to the return of a project. They must understand each investment so that they are able to make educated decisions. Companies hesitate with alternative constructions due to the large set of uncertainties. Using the concept of Building Information Modeling (BIM) and computerized analysis, it is possible to design construction projects as parametric models. The BIM models are parametric models, which help not only in visualization of the projects, but also show very detailed project timelines and budgets. Integrated systems of schedules and quantity takeoffs serve as a solid base for computer aided project management. Moreover, modern technologies can make energy consumption simulations on heating and cooling systems. These technologies provide developers with powerful tools for conducting comparisons and analyses and help them make educated decisions regarding their future projects. In

addition to the comparison analyses this research offers to developers some economic analyses that will help to evaluate returns on their investments.

Some of those methods will be discussed further in Chapters II and III. In Chapter II, along with the discussion about different types of student housing, sustainable architecture, and BIM concepts, the author reviews methodologies to evaluate financial returns. The author also provided some discussions about the structural integrity of shipping containers and the energy simulation techniques in Chapter II. In Chapter III, the author discussed the research methodology and the limitations of this research. In Chapter IV, the author provided the description of the design of the parametric model of student residence. He provided the description of three case studies for comparison analysis. In Chapter V, the author analyzed the data for the research and arrived at the conclusion.

CHAPTER II

LITERATURE REVIEW

Student Residence Types

There are four widely-used student-housing types: (1) dorms or residence halls, (2) student apartments, (3) private houses, and (4) community houses. Usually universities provide dormitory service as an accommodation for freshmen or international students. Dorm life is often dynamic and noisy - for example, neighbors, friends and visitors come and go throughout a day; the social aspect of dorm life means that students would not feel lonely, but it also cuts into their studies (Frost, 2014). Dorms typically are more expensive comparing to other accommodations of student housing. Therefore, most of the students living in dorms switch to other types of living facilities once they are no longer considered as a freshman.

College students need to consider a lot of things before making decisions on accommodations. Such decision can be arrived after comparing location, physical condition, number of roommates, number of bathrooms, bedroom size and so on (Riker and DeCoster, 2008). Most students are found to live in apartment buildings, simply because that type of student residences are prevailing around college campuses.

There are several reasons why developers chose to build apartment buildings. One of them is that it allows higher density of tenants, comparing to private housing.

However, density of tenants is not the only factor that developers are concerned while making a decision about their future projects. Although community housing allows even higher density of tenants, developers are very hesitant to build that type of housing, and the following paragraph describes the main one.

There are two types of community houses that are well-known in the United States: fraternity and sorority houses (Greek membership organizations). Although the goal of those communities is to enhance members' educational experience by emphasizing intellectual, interpersonal and social development, they are known for their "partying" life style (Page and O'Hegarty, 2006). Page and O'Hegarty (2006) surveyed college students consistently and concluded that fraternity and sorority members reported heavier and more problematic drinking patterns than the general college population. Therefore, that type of student housing is known for property abuse problems. For that reason it considered harder to maintain and develops hesitant attitudes of developers while making decisions about their new projects. Appendix B contains interview with local realty company manager, who another time supports this idea.

Frederiksen (1979) was emphasizing the significance of a student residence being developed not only as a place for students to eat and sleep, but also as a place that promotes students personal, scholastic, and social improvement through guided group living. Wallace (2012) in his research examined a philosophy of student housing, how it affects students' personal and intellectual growth, and development of a sense of community. He emphasized that housing management must develop a programs that supports living environment in which students' behavior is considered, and learning can take place (Wallace, 2012).

DeCoster and Mable (1974) stressed that physical nature of a residence highly contributes to student interaction and academic achievements. A few decades later Riker and DeCoster (2008) stressed that the educational role in college housing was found in two very basic but important assumptions. They are listed as follows: (1) environment influences behavior; and (2) learning is a total process. Riker and DeCoster (2008) showed that physical facilities can support educational process and contribute in important ways to student learning. That develops an idea that students need appropriate study, fellowship and recreational areas within their residences. The second assumption of Riker and DeCoster (2008) states the necessity to develop a students' personality and intellectual capacities and help students to grow culturally, spiritually and psychologically in societies and avoid isolation. Appendix A and Chapter 4 provide further deliberations on how to meet mentioned in this section recommendations for student housing.

Sustainable Architecture

Nowadays sustainable design is probably one of the hottest topics. Enormous amount of research have been done in that area. Keitsch (2012) stated that sustainable architecture challenged new and ingenious architectural design at various levels. Spheres of contemporary research in sustainable design include minimizing the negative environmental impact of buildings by enhancing efficiency and moderating the use of materials, energy and development space (Keitsch, 2012). Keitsch (2012) stated that sustainable architecture shall be well built, easy to use, and beautiful. But it is still hard to determine a set of characteristics that would clearly recognize one structure as sustainable and another as not sustainable (Maxman, 1993). Maxman (1993) emphasized -

“Sustainable architecture isn’t a prescription. It’s an approach, an attitude. It shouldn’t really even have a label. It should just be architecture”.

In architecture design, sustainability is a way to reduce houses’ impacts to the environment (Keitsch, 2012). Edwards and Hyett (2002) stated that it was not what buildings were but what they did and how they did it that was the major concerns to sustainable development. Housing is often identified as a reasonable contributor to concerns about energy consumption (Estes, 2011). Due to those concerns the technology market constantly tries to provide new technologies that are safe, efficient in energy consumption, and with reduced environmental impacts (Marsh, 2010). Governments provide guidance for these concerns which calls attentions from designers and engineers to implement sustainable technologies (Marsh, 2010).

Meanwhile, the technology market was so concerned with producing energy efficient tools and energy generating systems, some researches came to conclusion that different behavioral patterns can significantly reduce efficiency of those innovations (Guy, 2000). Example of using Compact Fluorescents (CFL) versus Light Emitting Diodes (LED) can give better understanding how user behavior affects efficiency. LED is considered extremely efficient lightening tool. But if there are two different users that behave differently, then even inefficient CFL can last longer in the hands of efficiently behaving user as appose to efficient LED in the hands of inefficiently behaving user. This issue raised a new wave on the technology market. Researchers started to pay attentions to users’ behavior factors during technology development process. For example, motion sensors would be a good solution to prevent over-usage of artificial lighting in houses.

Building Information Modeling

Architectural Design is not an easy task. In the conceptual design or design development processes, designers and architects might make a lot of mistakes. And those mistakes might be due to the lack of information or professionalism of the design team. Currently, computer model integration helps people to reduce errors and increase performance of the design and development process (Merschbrock & Munkvold, 2012). Software programs allow architects to hand-draw their ideas on paper and scan them into digital pictures start CAD drawings. With the increasing use of iPads and other tablet computers, designers can use the touch screen as paper and directly draw plans on the screens. Three dimensional modeling helped designers and architects to reduce time spend on sketching. Another significant benefit of 3D design is that it becomes easier to handle changes in design. There is no need to redraw all the drawings if a design is changed. With that aid, architect makes changes in one drawing and those changes automatically would be adjusted to all other drawings.

In the last few decades, construction world was able to observe significant involvement of Information Technologies (IT) in construction design (Merschbrock and Munkvold, 2012). Traditional paper-based approach was shifted into two-dimensional Computer Aided Design (CAD) and then the later one was shifted into three-dimensional technologies (Merschbrock and Munkvold, 2012). However, even three-dimensional technologies were not sufficient to meet the great needs of the construction industry. Building Information Modeling (BIM) technology can answer the demand for something more powerful than just visualization. Merschbrock and Munkvold (2012) discussed that BIM could be best described as a IT tool made to design virtual models that present

physical and functional characteristics of it. According to Kensek and Noble (2014), BIM has gained rapid acceptance in architecture and engineering schools, by building design and delivery professions, by the manufacturing and construction industries, and by building owners and managers. The main purpose of BIM is to integrate knowledge from various project participants that traditionally work in different phases of the building and maintaining processes.

Sebastian (2010) discussed that, the decisions made during design phase affected, on average, 70% of the life-cycle cost of a building. It is essential for collaborative design to rely on multidisciplinary knowledge for a building's life cycle. Traditionally, construction design services were delivered by multiple organizations when each party prepared paper drawings to cover one's particular area of expertise (Merschbrock and Munkvold, 2012). Using digital BIM platforms allows designers to associate data with geometry. Through that, designers can build parametric models for building design. BIM system developers designed the platforms so that architects, structural engineers, electrical engineers, plumbing and ventilation engineers, landscape architects, construction firms, and specialized subcontractors can be involved at design stage and provide benefits to projects with their knowledge (Merschbrock and Munkvold, 2012).

This methodology of integrated design opened wide horizons in developing more precise schedules and budgets for projects. Merschbrock and Munkvold (2012) discussed that in the late 1990s, the term 4D CAD was coined to describe applications combining BIM and scheduling functionality. Today this technology reached the level where users can view simulations of their project's schedule. Follower researchers argued

that by linking 4D animated schedules to cost information people can get benefits from 5D BIM.

BIM developers pay close attentions to different energy simulation software. Kensek and Nobel (2014) argued that there were significant improvements in building performance simulations over the past two decades. As a result of those improvements current BIM platforms can conduct not only energy consumption tests which help people to make optimal lighting solutions but also many other different simulations (i.e., wind load simulation) that all together contribute to efficient decision-making process.

Examples of widely used BIM software include: Autodesk Revit, Bentley Systems and Graphisoft. In this research the author will use Revit to develop student residences and conduct simulations to understand the best choice of materials for that type of project.

Autodesk Revit allows users to build digital models of their construction projects. Nassar (2012) mentioned that the use of Revit in construction estimating is gaining more ground as more contractors are using it to perform detailed construction estimates. A quantity takeoff is one of the most powerful and promising advantages that construction market can benefit while using Revit (Nassar, 2012).

Thermal Properties of Materials

Thermal conductivity is an ability of materials to conduct heat. The faster heat flows through material the higher conductivity it has. Thermal resistance of a material is calculated as an R-value to show its ability to resist heat flow (Gooch, 2010). It is measured in hours needed for 1 Btu to flow through 1 ft² of a given thickness of a material when the temperature difference is 1°F (Gooch, 2010). Thicker material has

higher R-value than a thin one. U factor is the reciprocal of R-value and usually used for assemblies Autodesk provides basic information about material's thermal properties. Every material used in an envelope assembly has fundamental physical properties that determine their energy performance such as conductivity and resistance. In order to make efficient design decisions designers should be aware of these properties.

Energy Consumption and Parametric Simulations

There are several factors that can affect energy consumption, including: heating-degree days, appliance efficiency, fuel substitution for space and domestic water heating, windows, energy-efficient lighting and heating, ventilation, air conditioning (HVAC) systems (Shrestha & Kulkarni, 2013), building envelope shape (Granadeiro, et al., 2013), and building materials (thermal mass) (Andjelković, et al., 2012). Andjelković, et al. (2012) concluded that simulation results indicated that by adding thermal mass to building envelope and structure, the following improvements can be achieved: (1) 100% of all simulated cases experienced reduced annual space heating energy requirements; (2) 67% of all simulated cases experienced reduced annual space cooling energy requirements; (3) 83% of all simulated cases experienced reduced peak space heating demand; and (4) 50% of all simulated cases experienced reduced peak space cooling demand (Andjelković, et al., 2012).

Construction cost of a concrete building is significantly higher than a building made out of wood (Mohamad, et al., 2009) or shipping containers. For the energy use in a building's life-cycle, it has been estimated that approximately 80% to 90% of energy use is consumed in the use phase of conventional buildings, while 10% to 20% is consumed by the material extraction and production and less than 1% is consumed through the end-

of-life treatments (Mohamad, et al., 2009). Therefore, when studying the feasibility of using shipping containers as a cheap source of construction materials, the author will calculate both the energy consumption to sustain indoor comfort and the construction cost of using shipping containers as building envelope.

When evaluating new construction materials, reduction of energy consumption is one of the main requirements (Bolotin, et al., 2013). Because modeling for energy simulation is a time-consuming task, frequently this process was simply overlooked (Granadeiro, et al., 2013). Nowadays developers now can receive benefits from all sorts of simulation software systems.

Examples of simulation software include: Green Building Studio, BEopt, Building Energy Modeling and Simulation, etc. In this research, the author will use Green Building Studio (GBS) to simulate energy consumption of a student residence. GBS is an Autodesk product that allows architects and designers to perform an extended building energy and water consumption analysis, and helps to make optimal decisions regarding carbon-neutral building designs (Green Building Studio, n.d.). The functions of GBS include; (1) it analyzes the entire energy-usage of the systems and provides energy cost projections; (2) it takes into consideration weather data based on the location of the project; (3) process is web based, therefore, its simulation process is rapid; (4) it is able to compare design alternative (Autodesk, n.d.).

Following is the lists of the advantages of GBS web service; (1) interface of the software is very user-friendly; (2) it saves designers time and effort to calculate a significant amount of information; (3) all of the simulations are carried out on remote servers; (4) provided results are easy to understand and can be easily compare with

results of different buildings design (Autodesk, n.d.). In the proposed research, GBS's ability to provide results for design alternatives is crucial. Using the results, the author can study how materials with different R-values can affect a building's annual energy consumption.

Return Evaluation

Simple Payback Method

Payback method is often used to find a breakeven point for financial analysis.

The method shows how fast investments will be recovered by cash inflows.

$$\text{Payback} = \text{Investment} / \text{Annualized Cash Inflows}.$$

Park (1997) mentioned that the payback method evaluates projects on the basis of how long it took net receipts to equal investment outlays without including any time value analysis. Usually managers would use this method for its simplicity (Estes, 2011). However, this method is not profitability metric (Russell, 2009). The simplicity of the method comes with a significant disadvantage. It assumes that an asset doesn't depreciate. In reality an asset depreciates over the time of exploitation. Also there should be an interest on the money spent on the investment. But payback method doesn't consider the interest or the depreciation of an asset.

Narayanan (1985) argued that "managers who use the payback method apparently prefer projects with quick returns". He proposed that there were some instances where only the quickest payback was important to managers. But it may not in fact be the best for the managers or the company.

Time Value of Money

Due to its earning capacity, money available today is worth more than the same amount in the future. Vanek and Albright (2008) argued that the change in value of money due to its depreciation over time span called time value of money. Some well-known time value of money analyses are: internal rate of return (IRR), modified internal rate of return (MIRR), and net present value (NPV). NVP time value of money method include: present worth, annual cash flow, future worth, inflation, depreciation, interest rates (Newnan, et al., 2004).

Discounted Payback Method

Discounted payback method (DPM) is more accurate in predicting time an investment takes for the owner to break even (Estes, 2011). This method takes into account time value of money (Estes, 2011). The difference between simple payback and DPM is that the cost and savings of an investment are discounted in DPM. “DPM is often correctly used as a supplementary measure when project life is uncertain” (Kreith & Goswami, 2007). Simplicity is a major advantage of DPM method over other time value of money analyses. However, Ester (2011) concluded that DPM method and simple payback method neglect any profit the asset will bring to the company after the breakeven point is reached.

Shipping Containers’ Structural Integrity

There is very limited literature about feasibility of using shipping containers for dwelling purposes (Giriunas, Sezen, & Dupaix, 2012). Figure 1 shows the structural elements of 20’ ISO shipping containers. Containers are designed to make vertical contact with each other through discrete corner fittings (Cooper, et al., 2003). A safe way

to make a multistory building out of containers should take the contact points into consideration. According to ISO Standard 1496/1, corner post should be able to bear up to 190 kip loads (Cooper, et al., 2003). Typically a steel corner-post corresponds to the specification of American Society for Testing and Materials (ASTM) A-572 steel with a yield stress of 47 ksi (Cooper, et al., 2003). Corner fittings are actively involved in vertical contact as well. Those elements are made out of A-216 steel with a yield stress of 40 ksi (Cooper, et al., 2003). The maximum load that one corner can bear is 200 kip (Cooper, et al., 2003). Giriunas, et al. (2012) analyzed shipping container's structural integrity under different structural modifications for different loading patterns. Analysis reveals that non-modified container's post (under equally distributed loading scenario) is going to yield only at 212 kip (Giriunas, et al., 2012).

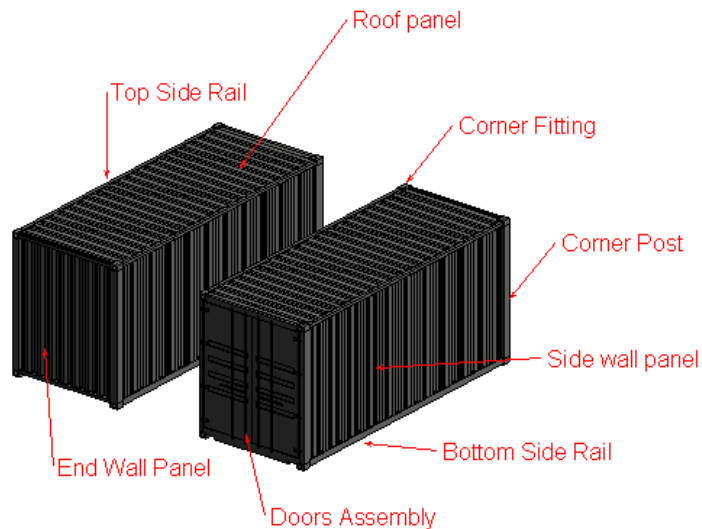

Figure 1. 20' ISO Shipping Container's Elements.

Table 2. *Comparison of Container's Components Durability against General Wind Loading Requirements (Residential Shipping Container Primer, n.d.).*

	20' container's capacity	Required
Wind loads requirements (buildings less than 50' tall)		
Side walls	196 psf	20 psf
End wall/doors	370 psf	20 psf

Containers have box shapes and require some modifications when used as structural components for residential dwellings. There are two main problems when modifying the structure of a container. The first is that the container may lose its structural strength. The second is that steel modifications are usually very expensive. Therefore, in the design of the proposed residence, the author considered the minimum amount of containers' structural modifications.

Giriunas, et al. (2012) revealed that with equally distributed loads on the four corner posts of a container, the complete removal of the end-wall panels and door assemblies (Figure 1) is the less desirable type of modification compared to the removal of the side-wall panels. A container with only the side-wall panels removed is able to withstand the loads up to 212 kip; but a container with the end-wall panels and door assemblies removed is able to withstand only up to 168 kip (Giriunas, et al., 2012). This information was considered as a basis for the structural design of the student residence in this research. The author presented the detailed information of the load-bearing structure in Chapter IV.

CHAPTER III

METHODOLOGY

Materials, Tools, Software and Data

Application of Autodesk Revit Architecture

A construction estimating process can be performed in two steps: quantification and pricing. Autodesk Revit provides a quantification function. However, the software does not generate automatic cost estimates. The more details the digital design can get, the more precise quantity takeoffs of the project will be. Revit still needs certain level of abstraction of the real building or facility (Nassar, 2012). This means that some form of cost aggregation has to take place at a certain level (Nassar 2012).

Nassar (2012) listed several cost estimating techniques in his work. However, he emphasized two basic categories: (1) element based estimation, (2) activity based estimation. The second type of estimation is a mimic of a real life project where project managers break down projects into tasks or services and assign materials, labor, and equipment requirement to each activity. This method provides accurate estimates, but it is very detailed and requires much effort for the conceptual design stage. Nassar (2010) discussed the application of RS Means construction data base. This database has cost elements for tasks based on quantity. It offers information about the crews required for the performance of certain tasks and their productivities, which allows users to estimate

the tasks' durations. In this research the author will use the data provided by RS Means database.

Autodesk Revit has the functions of element development. For instance, a wall creation process consists of several steps. First, a user needs to understand how many layers a wall should consist of. For example, Revit offers heavy structured walls, such as 2' 2½" thick; and "Exterior - Insulated Concrete Masonry" wall that consists of 7 layers including 2 layers of concrete masonry, two types of thermal insulation, water resisting membrane, metal furring, and gypsum. The next step would be to assign function, material, and thickness to each layer. The element development function of Revit is going to be used in this research to create desired insulation for exterior walls, floors and roofs of the residence.

Another helpful feature of Revit is that the software allows the creation of desired components in the forms of separated families that can be loaded in the parametric model of the residence. This feature will be used in order to create modified shipping containers and assign materials to these components.

The consistency feature of Revit allows the different crews that are working on the design of the parametric model to work independently from each other; and then share their work with each other. For example, using this feature, civil engineers work on the development of a project's structural design. Meanwhile, electrical, plumbing, and HVAC contractors work on the development of their portions of the project. Eventually they can submit their portions of the project model to the design coordinator or architect in form of separate links. Next, an architectural crew links all these separate pieces to the main model or master file and analyzes the entire project design. This feature of Revit is

very helpful if a project file becomes very large in size as new elements are added into it. In this research, the author will develop three separate files that can be linked to form the whole residence design.

Simulation Process

After the completion of the 3D models of the residence with all areas and volumes being defined, the author will perform the energy consumption simulations. It is a web-based external building performance simulation that is performed using GBS. GBS is a web-based application which can analyze gbXML type files that are exported from Autodesk Revit. All the building geometry comes from the Revit model, including the number of rooms and their relationship to the exterior. The user needs to provide some building information like building type and postal code.

After all the information is collected, GBS would be used to provide a complete building energy analysis, carbon-emission estimates, water use, and cost estimates, Energy Star scoring, LEED daylight credit potential, natural ventilation, and thermal performance (Autodesk, n.d.). The most important piece of data provided by GBS is the annual and lifetime energy costs. The author would use this data to develop a series of cash outflows in the economic model of the research.

Economic Analyses of the Residence

The author will apply an analytical tool to help investors to understand: (1) the investment return period, (2) profitability, and (3) the profit region (Estes, 2011). The focus of this research is on the analytical tools that consider time value of money analysis (TVM). One of those tools is NVP. NVP economic analysis was discussed by Lucko (2013) as a valid way to value the cash flows for TVM. Internal Rate of Return (IRR),

Discounted Payback Method (DPM) and Profitability Index (PI) are three additional tools that help measure profitability, its range, and investment return period.

In order to determine the lifetime of a project, the author uses a system adopted by the United States Internal Revenue Service. The system is known as Modified Accelerated Cost Recovery System (MACRS) and is used for calculating the depreciation of an investment (Newnan, et al., 2004).

Determining the cost of capital is not easy. This is especially true for small realty companies or even individual investors. The author will use S&P Capita IQ statistics as an approximation for discount rates for TVM analysis.

The author will also consider inflation rates in the investment analyses. Even small rates of inflation over time can have significant effects on a project's value (Estes, 2011). Consumer price index (CPI) is a well-known parameter that is used to measure inflation. The author will incorporate the inflation rate in the TMV analyses by adjusting each of annual cash inflows/outflows to CPI index. CPI index will be selected on random out of normal distribution generated based on 30 years CPI mean and standard deviation.

Data

The author will use Autodesk Revit in order to create two parametric models of the residence (see Chapter II, Section Student Residence Types). One of these models will serve as a model for visualization and budget estimation purposes. This model consists of a main file and two linked files. The main file is developed using standard features of Revit. The first link is a residence model that contains only modified shipping containers that are used for the design of a residence for the current research. The second link is a structural design of the residence.

The second model will be created to conduct an energy simulation for the current residence. In this model, the walls, floors, ceilings and roof of the building imitate the design of the residence. For example, if the design requires having an exterior wall of R-20 for thermo-resistance, then R-20 wall is placed instead of the shipping container's wall. This approach allows creating a proper parametric model that is going to be understood and recognized by GBS. The complication is that in order to make a full building energy simulation, all the rooms, areas and volumes have to be recognized by the GBS. However, the proposed model will contain shipping containers and a significant amount of nontraditional walls, floors and ceilings, the software may not be able to recognize. For that reason, it is impossible to run a GBS simulation on the same model. Using BIM technologies, the author will obtain cost estimates for the initial investment and energy cost data for the life time of the project. Further the author will use this data as a cash outflows for economic analysis. For economic analysis the author will use Microsoft Excel. Other missing parts for that analysis would be project life time, discount rates, inflation and projects' income. Chapters IV and V contain further details on these components of analysis.

MACRS is a system that determines the depreciation period of an asset. In accordance with this system, Residential Rental Property assumed to be depreciated within 27.5 years. The author will round this period to 28 years for simplification purposes. After the calculation of NPV, IRR, DPM, and PI figures for the alternative materials of student residence, the author will analyze the same analytical tools of the existing properties that are made in a conventional way. The data about existing properties is obtained from case studies (see Chapter IV, Section Case Study). Based on

the results of the economic analyses the research question of whether shipping containers could be used to replace the structural components of traditional construction for student housing will be answered.

Research Limitation

There are three limitations in this research. The first is the approximation of using consistent thicknesses on walls, floors, and roofs for all the shipping containers used in the simulation model. Though Autodesk Revit is a very flexible program, it is challenging to build a parametric model of student residence made out of ISO shipping containers.

The second limitation is to use fixed numbers for project life-cycle duration and annual interest rate of return. In reality, those figures can change throughout time. To simplify analysis the author will use figures for annualized cash flows.

The third limitation of this research is that there are certain uncertainties for the cost estimates of construction. For example, this research doesn't provide detailed design of plumbing, mechanical, electrical, HVAC and sprinkling systems. The author will conduct cost estimates based on square footage of the building or based on the average percentages of the building elements in budget estimates of similar projects.

Chapter Summary

This research investigates the benefits of implying alternative construction method in student housing. The author will develop a student residence using ISO shipping containers as an alternative structural component. The author will use Autodesk Revit to build parametric models of the residence. He will use Green Building Studio for energy simulation analyses and comparing energy usage by alternative building types

versus that by traditional buildings. He will use economic evaluation models to calculate the project financial breakeven and project profitability.

CHAPTER IV

RESEARCH DESIGN

Case Study

In this section, the author will present case studies on existing properties. All of the buildings in the case studies were built after 2008. The first two projects were located at the off-campus area of Illinois State University. Both of them were in approximately 5 minutes walking distance from the campus. These two properties were managed by Young America Realty, Inc.

The first property was called “The Lodge on Willow” and located at 214 W. Willow in Normal, Illinois. This property was constructed during the period of May 2011 to June 2012. It was considered as a luxury student housing with an outdoor pool and a 4600 ft² clubhouse as a form of a common fellowship areas (for details see Appendix C, Case study #1).

The second property was “Covington Apartments”. It was located at 102 W. Cherry, Normal, Illinois (for details see Appendix C, Case study #2). It was built during the period of October 2012 to August 2013. This residence was also considered as a luxury student-living facility with covered parking located under the residence.

The third property was called “Crosswalk Commons”, managed by Crosswalk Project, Inc. with a support of Salt and Light Christian Fellowship (SLCF). It was located

at 925 Hilltop Drive, West Lafayette, Indiana (for details see Appendix C, Case study #3). It was built during the period of September 2012 to August 2013. This property had managerial personal who was working on students' social and spiritual development. Although the rental policy of Crosswalk Commons was very narrow and focused mainly on international students (see Appendix A), it did not have many vacancies. The residence was known for its very friendly and loving atmosphere and highly desired by the international students of Purdue University.

Tables 3 and 4 provide comparisons of the three aforementioned residences. This information, together with Appendix C, will be used to calculate analytical coefficients. Due to the inconsistency of the residencies' construction periods and locations, RS Means' historical and location indexes were used to derive the national average project costs in 2014 (see Table 3). More detailed information about rental costs, rental conditions and the pictures of those three student-residences can be found by following the links provided in Appendix C.

Table 3. Adjusted Construction Cost of Analyzed Properties.

Residence name and the year of completion	Construction Budget (million \$)	Historical Cost Index	Construction Budget (million \$) as of 2014	City Cost Index	Construction Budget (million \$) as of 2014, National average
The Lodge on Willow as of 2012	\$13.40	194.6	\$13.96	103.6	\$13.47
Covington Apartments as of 2013	\$3.09	201.2	\$3.11	103.6	\$3.00
Crosswalk Commons as of 2013	\$5.57	201.2	\$5.61	90.5	\$6.20

Estimated Historical Cost Index as of 2014 - 202.7

City Cost Index as of 2014 for National average - 100.0

Historical and City Cost indexes obtained from RS Means building construction cost data 2014 (2013). City Cost Index if Champaign, IL is used as an approximation for Normal, IL.

Table 4. General Information about Analyzed Properties and Their Analytical Coefficients. (See Appendixes D, E, and F)

Residence name	Construction Budget (million \$)	Construction beginning	Construction end	Construction duration (in months)	Residence type
The Lodge on Willow	\$13.47	May-2011	Jun-2012	13.00	Town houses
Covington Apartments	\$3.00	Oct-2012	Aug-2013	10.00	Apartments
Crosswalk Commons	\$6.20	Sep-2012	Aug-2013	11.00	Apartments
Residence name	Square footage (ft2)	Living area (ft2)	Number of Apartments	Number of Beds	Number of floors
The Lodge on Willow	160,000	150,000	79	307	3
Covington Apartments	32,000	26,500	16	56	5
Crosswalk Commons	44,000	31,000	32	120	4
Residence name	Shared Area/bed	Budget/ft2	Budget/bed	Annual energy cost	Energy cost/bed
The Lodge on Willow	32.57	84.2	43,885	\$120,000	\$390.88
Covington Apartments	98.21	93.9	53,658	\$23,000	\$410.71
Crosswalk Commons	108.33	140.9	51,672	\$45,000	\$375.00

The Lodge property had the best budget per square foot and per bedroom coefficients. The building had mostly wood framing sheeted with stone veneer. Covington was made of the same type of siding as The Lodge. They all had wood framing and brick veneer. However, the square footage cost of Covington was 10.3% more expensive because of the parking on the ground level of the residence. Covington had combustible barrier built between the parking level and the upper levels.

The most expensive case was the Crosswalk project for two main reasons. The first reason was that developers used a large amount of stone masonry and aluminum siding materials. The second reason was that the residence had the largest Shared Area per Bed Coefficient. The developers of the Crosswalk project dedicated a lot of the building's space to fellowship purposes. Crosswalk had relatively comparable Budget per Bed Coefficient due to very small Square Footage of apartments.

The Lodge project was three stories tall all around and included 307 beds. It had a larger footprint of the property than those of the other two. It is not the best solution for the areas with expensive land. On average all the residences were built in 11 month and its average cost was \$106.3 per square foot or \$49,738 per bed.

Those averages are targets of the proposed research. If it is possible to build a student residence using the alternative structural components without exceeding those coefficients, it is important to continue to develop this study for the reduction of environmental pollution, reduction of unused shipping containers that are currently stored at the areas that potentially can be used in more efficient ways, and motivating developers to build new student housing and meet market demands.

Residence Design Methodology

Following the studies of Frederiksen (1979), DeCoster and Mable (1974), Wallace (2012), and Riker and DeCoster (2008) it was decided to design a building with following facilities: (1) multi-purposeful fellowship areas, (2) studying areas, and (3) physical recreational areas.

When designing the student residence, the author decided to make minimum structural modifications to the shipping containers to keep its structural durability. The author used the high cube 40' ISO shipping containers to design the structural framing of the residence. Table 5 shows the specification of dimensions and weights of shipping containers. The idea is to combine conventional construction with alternative structural component of the building. This approach allows the partial elimination of the difficulties of rough-in work and achieves the benefit of cheap structural elements of a building.

Table 5. *Specification of Dimensions and Weights of Shipping Containers* (Giriunas, Sezen, and Dupaix, 2012).

Container type	Length	Width	Height	Empty weight
External dimensions				
40' High Cube	40 ft.	8 ft.	9 ft.-6 in.	8645 lb.
Internal dimensions				
40' High Cube	39 ft.-4.375 in.	7 ft.-7.75 in.	8 ft.-8.5 in.	
Minimum door openings				
Height		Width		
8 ft.-5 in.		7 ft.-6 in.		

Design and Modifications

Inspired by the interviews with a general manager of a local realty business, the author decided that each apartment should have 4 bedrooms, 2 full bathrooms and a kitchen. None of the apartments would have living rooms, which would motivate students to spend more time using the common areas of the residence.

For customer satisfaction, the author decided to equip each apartment with a stackable washer and dryer system instead of having a common laundry room. The selection of the stackable system was for the purposes of efficient internal areas usage. In order to meet the requirements of “The American with Disabilities Act (ADA)”, one of the bathrooms in a unit would have a 60” diameter circle in the middle to accommodate the wheelchair inside the bathroom (Rodriguez, n.d.).

Every bedroom would have a twin size bed, a desk, a chair, and a closet. This bedroom configuration would be optimal to meet the daily needs of a student. The bedrooms would have large windows for natural light. The internal height of a high cube shipping container is 8ft.-8.5in. The author designed a dropped ceiling with a 12-inch offset for electrical and ductwork to be installed above the ceiling. A containers’ width is only 7ft.-7.75in. The corrugated side walls of a shipping container can serve as a great base for the internal finish such as a gypsum drywall. Therefore, the author decided to install drywalls directly on the corrugated steel, except for those areas where insulation is needed. The plan view of the designed apartment is shown in Figure 2.

As shown in Figure 2 and Figure 3 the apartment design consists of three 40’ containers. The second 40’ container sticks out by 8’ to the left of the other two 40’ containers. This design idea makes space for a 13’ long and 8’ wide area at the right part of the apartment for 2 full bathrooms. The average footprint of the 4 bedrooms would be of 150 ft².

To avoid the removal of end walls and door assemblies, the first 40’ container that has two bedrooms has two large 6’ by 3’ windows opening along one of the side walls. Also this container has a 12’ by 8.5’ opening along another side wall. Figure 4

shows the details of the 12' X 8.5' opening. This large modification is to connect the three containers into one apartment.

Container 2 in Figure 5 has one bedroom, one small hall-way area and a part of a bathroom with a shower. As shown in Figure 5, this container's door assembly has been completely removed. Both side walls have the large 12' X 8.5' openings. One side wall has 6' X 3' window opening. As it can be seen from Figure 2 there is a containers front bottom framing component sticks out by approximately 2 inches. Due to floor level requirements of this design it was not possible to cover this element under the floor finishing material. This component can be decoratively painted to fit the interior design of the bathroom.



Figure 2. Apartment Layout (Plan View).

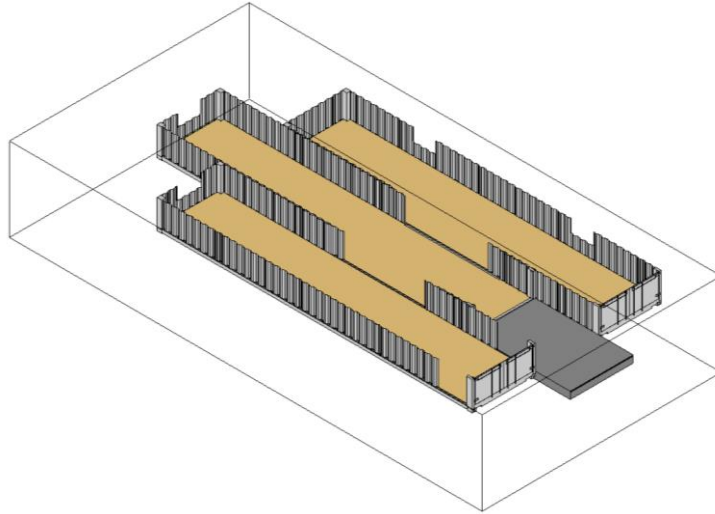

Figure 3. *Apartment Layout (Perspective View).*

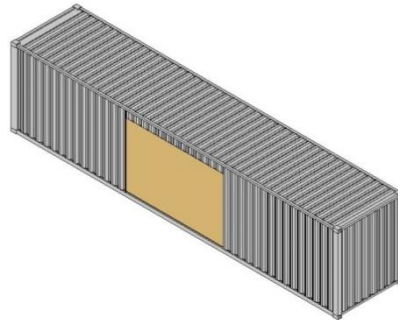

Figure 4. *First Modified 40' Shipping Container.*

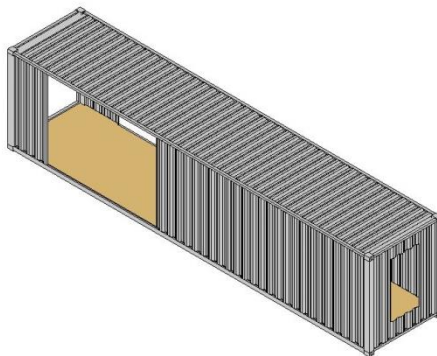

Figure 5. *Second Modified 20' Shipping Containers.*

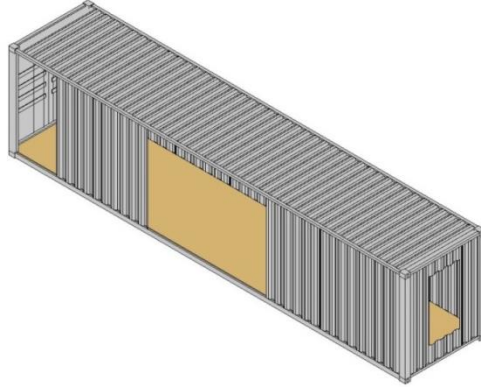

Figure 6. *Third Modified 40' Shipping Container.*

Figure 6 shows the details of Container 3. This container has one opening along one side wall and two 3'-8" wide openings for an entry door and a bathroom door. There is another 6'x3' window opening on the end wall of the container.

The interior design of the project reflects a minimalistic approach. Gypsum drywalls are used as walls' and ceilings' finish material. Shipping containers usually have marine plywood, with possible toxic treatment applied to it. In that case, the material cannot be used for dwelling purposes. The information of the material can be found by checking the data on the container's data plate. Although in this research, the author assumed that the flooring plywood is not treated with any of the harmful chemicals, budget estimates will allow some room for that type of expenses. The flooring plywood can serve as a perfect rough floor itself. But it would be esthetically pleasurable to apply some flooring finishes. The proposed design offers carpet finish for bedrooms and vinyl tiles for kitchen. There is a 10 ¾" floor that is made in traditional way in between containers 1 and 3. It serves as a platform for the bathrooms of the apartment. As shown in Figure 7, this area has a ceramic finish material. The floor is structured with 9 ¼" wide wooden-joists installed on heavy joist-hangers, which are respectively installed on

the bottom side rails of the 40' containers. It is covered with 3/4" plywood sheathing. The conventional floor of the apartment sticks out by 5' on the right side of the apartment.

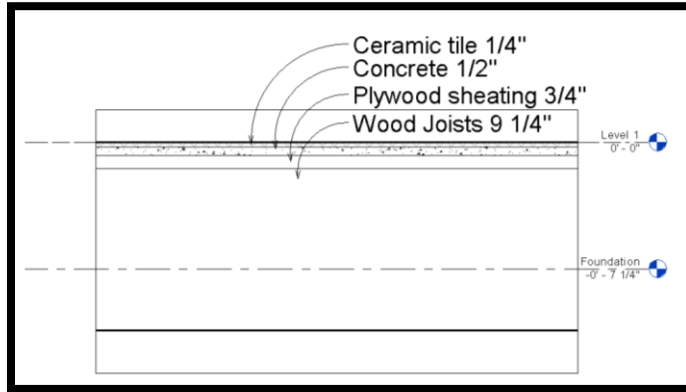

Figure 7. Apartment's Conventional Flooring for Bathroom Area.

The partition walls are for the space-separating purpose. They are structured from typical 2x4 framing wood and finished with 1/2" drywalls from each side. Wood framing is usually the structural component of a wall and necessary for a conventional residential construction. In this research, the corrugated walls of a shipping container can serve as a solid structural component that is able to carry the weight of the drywalls.

Insulation

The residence design requires insulation for the following items: (1) the walls that are in contact with the environment, (2) the floors of the first level, and (3) the roof of the residence. In according with the Residential Prescriptive Requirements (2009), Illinois is in zone #5. The zoning requirements and the related R values are listed in Table 6. See Appendix G for construction and insulation materials' R values.

Table 6. Insulation Requirements for Zone#5 (Residential Prescriptive Requirements, 2009).

Component	Requirement
Wall's R value	20
Floor's R value	30
Roof's R value	38

There are several ways to achieve R20 level of insulation of exterior walls. A traditional way is to use wood studs and fiberglass insulation. Usually fiberglass provides R11 at the thickness of 3 ½” (Energy.gov, 2015). In that case, it needs to have approximately 6 ½” thick of fiberglass as the insulation layer in order to achieve R20 requirement. To maintain the dimensions of the constrained inner volumes, it would be rational to minimize the thickness of the insulated walls. For example, R20 would be achieved at 5 ¼” thickness if high density fiberglass is used (Energy.gov, 2015). But the significant drawback of that type of insulation is that the walls of a shipping container are made out of corrugated steel. With fiberglass insulation, there will be cavities that will cause condensation.

An alternative idea of insulation is to use spray-foam insulation. Although spray-foam insulation (i.e. Polyurethane foamed-in-place) is one of the most expensive alternatives, it provides R6.25 per inch of thickness (Professionals Corner, n.d.) and R20 can be achieved at 3 ½” of thickness. This type of insulation will take care of the cavity problems and create solid continuous insulation. For details of the discussion on the spray-foam insulation, see Appendix B, Interview#2. The combination of both types of insulation materials, i.e. spray foam and high density fiber-batt, takes care of the cavity problems and provides the required level of insulation at reduced cost.

In this design, the drywalls for the internal walls can be installed directly on the corrugated steel walls of a shipping container. But it is difficult for the exterior walls to have the same installation due to insulation requirement. Therefore, the framing for the exterior insulated walls is still required for the support of drywalls. Figure 8 show the section view of a typical insulated wall of the design. Table 7 lists the R value.

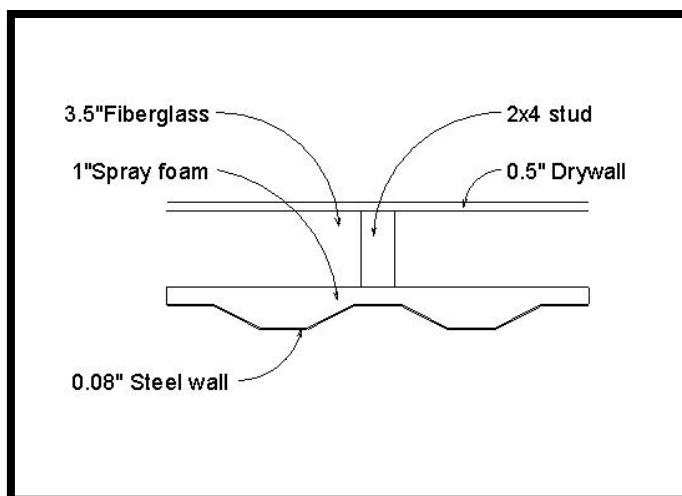

Figure 8. *Insulated Wall (Plan View).*

Table 7. *Insulated Wall Assembly's R Value (Professionals Corner, n.d.).*

Thickness in inches	Component	R value of a stud	R value of a cavity	Assembly R value
N/A	Outside Air Film	0.17	0.17	
2/25"	Steel Corrugation	0.33	0.33	
1	Spray foam	6.25	6.25	
3 ½"	High-density Fiberglass		15.00	
3 ½"	Wood stud (2x4)	4.38		
½"	Drywall	0.45	0.45	
N/A	Inside Air Film	0.68	0.68	
N/A	Percent for 24" o.c. + Additional studs	6.25%	93.75%	
	Total wall Component R value	6.00	22.88	
5 2/25"	Total Wall Assembly R Value			21.82

For the floors on the first level a shipping-container building, if a concrete slab is installed below the container floor, there is almost 6" cavity between the slab and the container floor (Crepeau, 2009). This cavity can be filled with foam spray, to obtain R30-R32.5 insulation, the thickness of the foam spray should be at 5 inch (Professionals Corner, n.d.). R30-R32.5 satisfies the insulation requirements for exterior floors.

In the designed BIM model, the author decided to build a flat roof that consists of two different roofing types. One type is lying on the top of a shipping containers and

the other is hanging above fellowship area of the residence. The main differences between the two types of roofing are roof thicknesses, types of insulation, and interior finish materials. Thus the following tables present the roof assemblies of both roof types.

Table 8. *R Value of The Roof that is above Shipping Containers* (Professionals Corner, n.d.)

Thickness in inches	Component	R value of a stud	R value of a cavity	Assembly R value
	Outside Air Film	0.17	0.17	
1/4"	EPDM*	0.44	0.44	
3/4"	Plywood	0.94	0.94	
7 1/4"	Wood Joists	9.06		
7 1/4"	High-density Fiber Batt		31.18	
2	Spray foam	12.50	12.50	
	Percent for 24" o.c. + Additional studs	6.25%	93.75%	
	Total wall Component R value	23.11	45.23	
10 1/4"	Total Wall Assembly R Value			43.84

Table 9. *R Value of The Roof that is not above Shipping Containers* (Professionals Corner, n.d.)

Thickness in inches	Component	R value of a stud	R value of a cavity	Assembly R value
	Outside Air Film	0.17	0.17	
1/4"	EPDM	0.44	0.44	
3/4"	Plywood	0.94	0.94	
11 1/4"	Wood Joists	14.06		
11 1/4"	High-density Fiber Batt		48.38	
1/2"	Drywall	0.45	0.45	
	Inside Air Film	0.68	0.68	
	Percent for 24" o.c. + Additional studs	6.25%	93.75%	
	Total wall Component R value	16.74	51.06	
12 3/4"	Total Wall Assembly R Value			48.91

The HVAC, Plumbing, Electrical and Fire Sprinkling System Design

Several HVAC (a.k.a. heating, ventilation and air conditioning) options were considered for the development of the apartment building of this research. The whole residence is not large enough to install a centralized system with zoning. For that reason,

a separate HVAC unit is designed for each apartment. The indoor fan coil unit above ceiling for the HVAC system is installed in the hallway area next to each apartment. This position is chosen in order to minimize ductwork. The ceiling fan coil of a HVAC system is only 11'' wide and can easily fit into the 1' cavity below the floor of the upper level and above the ceiling of the apartment unit. Figure 9 shows the location of the ceiling fan coil. The duct of the system distributes air to all bedrooms, bathrooms and kitchen of the unit. The return-air register is installed right under the fan as shown in Figure 10.

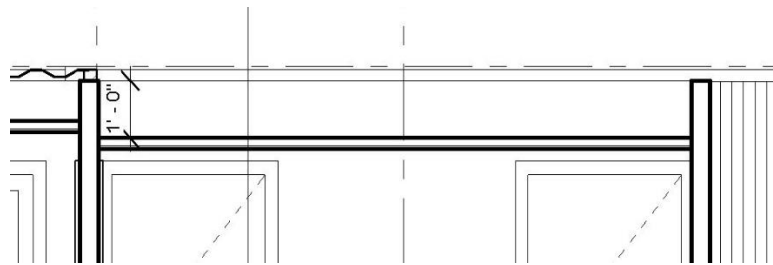

Figure 9. *Ceiling Drop in a Hall (Cut View).*

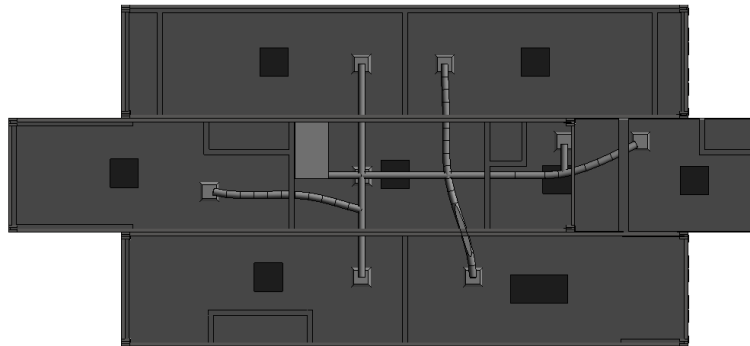

Figure 10. *Apartment Ductwork.*

The plumbing system of a conventional construction has various elements. All the piping can be distributed in the cavities of the wood-frame walls and floors. To provide enough space for plumbing pipes, the author designed 8' ¼'' wide plumbing wall as a separator for two bathrooms. Figure 11 shows the location of the plumbing wall. This plumbing wall supports stack pipes (e.g. main stack and vent stack), traps, and small cold and hot water pipes. Pipes connecting the washer of the apartment unit run through

the location of Connection A as shown in Figure 11. Those pipes go above the ceiling into the plumbing wall. A 23-gallon residential water-heater is installed in the ADA bathroom. It is connected to the main water line through the cavity in floor framing. The pipes from kitchen sink and dishwasher run to the plumbing wall at Connection B as indicated in Figure 11. The wall is 2''x4'' wood-framed wall that is installed along the container's wall (Connection B).

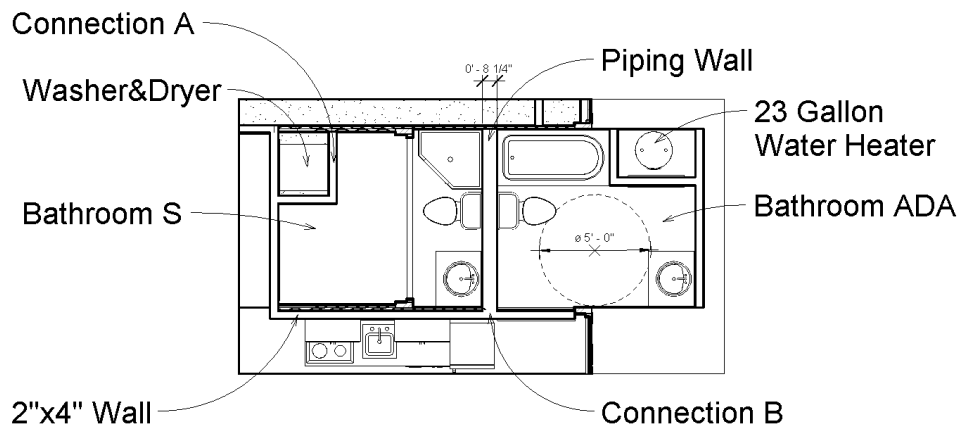

Figure 11. *Plumbing System.*

For the purposes of simplification, the author didn't include the detailed design of fire sprinkling system. However, with the integration of the conventional construction components and shipping containers, the sprinkling system can be installed in a very similar way to the rough-in work of the ductwork and plumbing system.

Connections

There are two types of connections: (1) vertical connection and (2) horizontal connection. Double-ended twist locks are used as vertical connectors for the shipping containers. The connection devices can lock containers together through their corner fittings. Figures 12, 13, and 14 show the details of the connections (Giriunas, et al., 2012).

There are many different types of horizontal connections that are widely used during stacking and transportation using shipping containers. However, it is impossible to apply those connections in this BIM model because containers are not aligned with each other in a horizontal line. Therefore, the author decided to use bolts and nuts system to connect containers through the side walls of the containers.



Figure 12. *Containers Stacked on Connection Device* (HEDD engineered design, n.d.).



Figure 13. *Double Ended Twist Lock* (HEDD engineered design, n.d.).

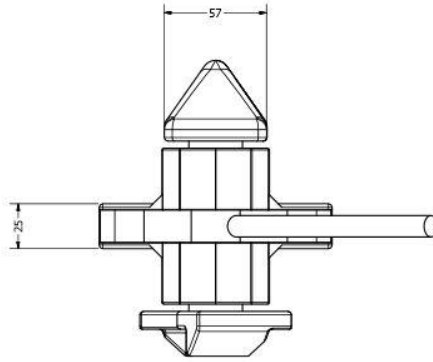

Figure 14. *Double Ended Twist Lock Dimensions* (HEDD engineered design, n.d.). Note 25mm=0.98in.

Structural Design

The design of the residence includes recreational, studying and fellowship facilities. Those areas are located in the core of the building. Thus the first and fourth levels have the recreational and fellowship areas respectively as shown in Figure 15. Each 40' container has 4 studying rooms. Studying rooms are available on all levels except the first and the fourth ones.

This specific design includes the structural elements, such as columns, beams, joists, etc. To enhance the preciseness of the budget of the design, the author developed the structural BIM model of the residence using concrete and wooden elements as shown in Figures 16 and 17. This specific structural design is for the purpose to compare the budget difference of the building using conventional materials and the building using shipping containers. The BIM model of the building using conventional materials does not represent any real case scenario. Its budget figure is shown separately and can be adjusted following the same design requirements of the building using shipping containers.

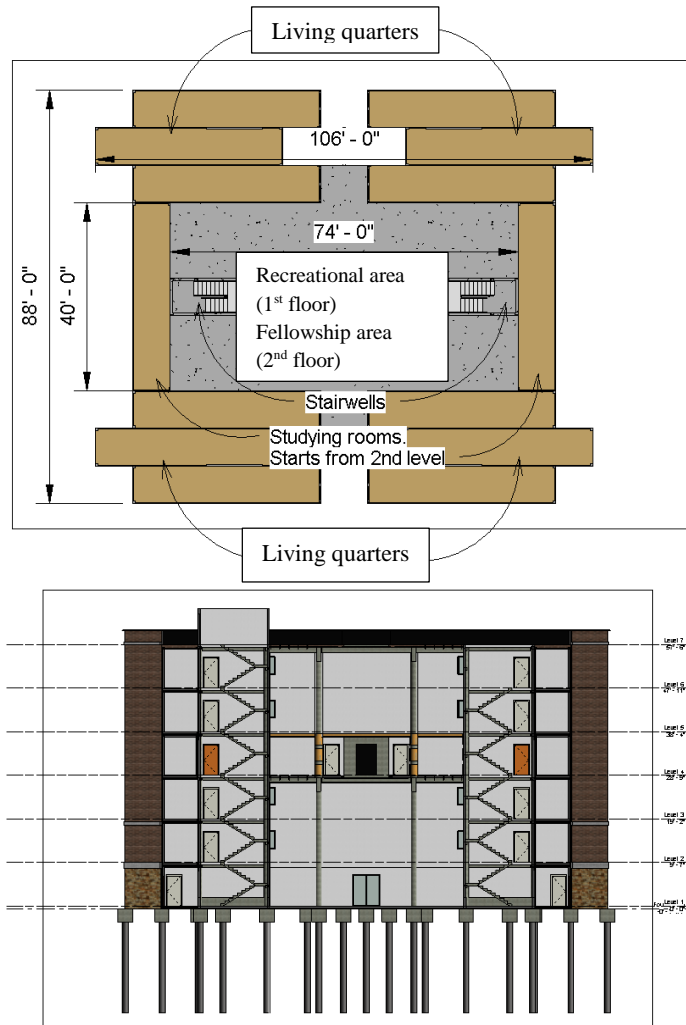

Figure 15. Residence (Plan and Elevation Views).

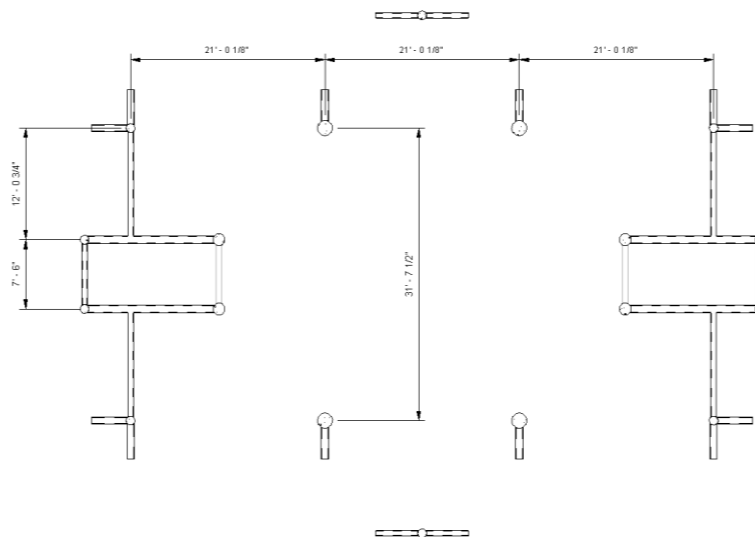

Figure 16. Structural Framing (Plan View).

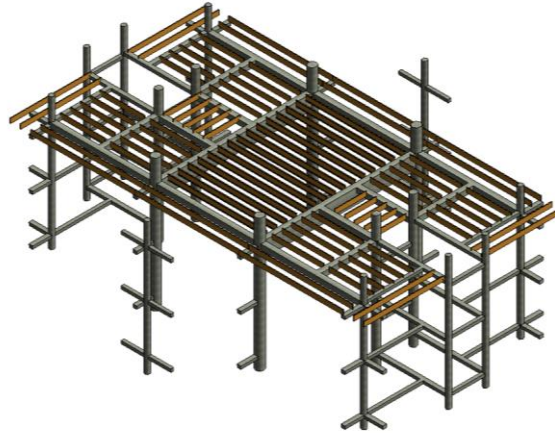

Figure 17. *Structural Framing (3D view, 2nd, 3rd, and 4th levels).*

The BIM model of the conventional building has recreational facilities and corridors on the first floor of the residence. Its floor slab doesn't require any structural support. This design of the floor slab includes 4'' thick slab on 4'' thick sand, reinforced by metal rolled-mesh and finished with 3/4'' of a rubber cover as shown in Figure 18 for the gym area and with 1/2'' carpet for corridors.

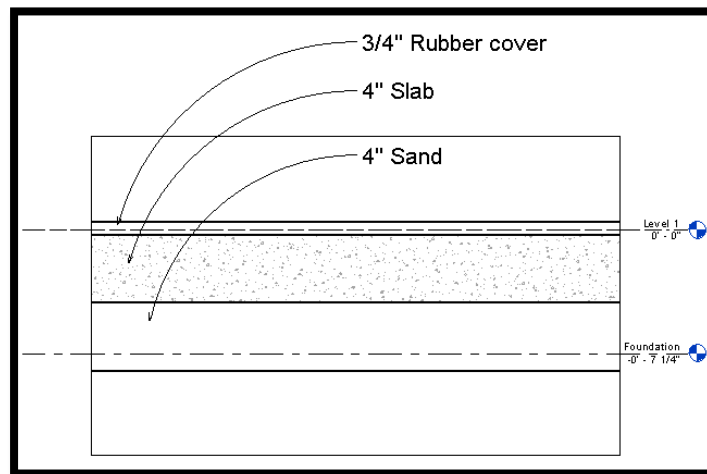

Figure 18. *Recreational Area Floor Design.*

The floor of the fourth level of the residence has the common fellowship area. There are 3/4'' thick plywood sheeting installed above 14'' wide wooden I-beams for the areas of 21' wide span. There are 2x12 dimensional lumbars for the areas with 12' span.

All lumber materials are placed on 24'' distance on center. Figures 19 and 20 show the details of those areas. The flooring finish of those areas is ½'' thick carpet.



Figure 19. *Fellowship Hall, Floor Framing (Plan View, Level 4).*

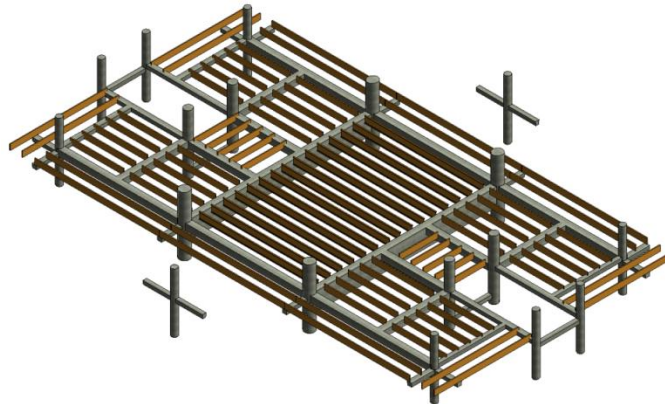

Figure 20. *Fellowship Hall, Floor Framing (3D View, Level 4).* Note: Brown and gray colored elements represent wood and concrete framing materials respectively.

The elevator is placed between two containers and supported by the corner posts of the load-bearing containers from two sides. The back side of the elevator isn't supported. In order to support the elevator, the author designed a concrete column with joists. Figure 21 shows that this system also secures containers through horizontal connections by welding. Stairwell rests on the concrete structure as shown in Figure 22. There are two stairwells in the residence. They are locked in the 6'' nonstructural wood-framed walls as shown in Figure 23.

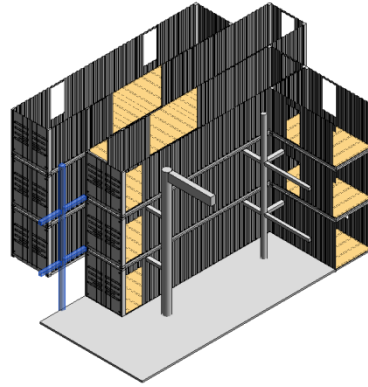

Figure 21. *Elevator Shaft Design.*

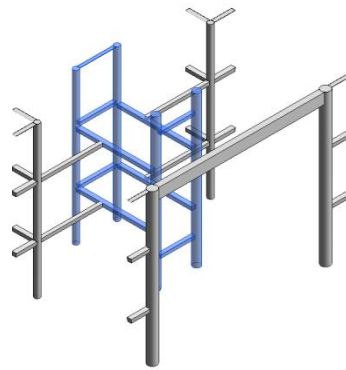

Figure 22. *Stairwell Concrete Structure.*

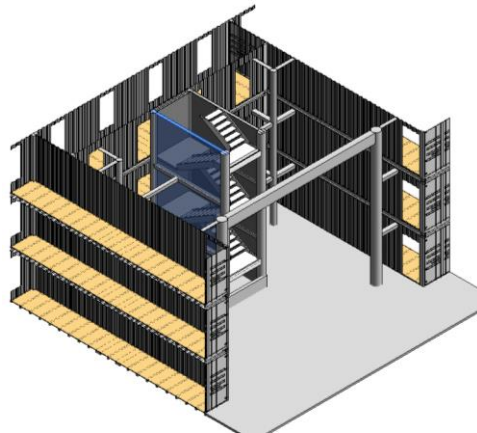

Figure 23. *Stairwell Design.*

There are two types of roofing materials in the BIM model. Both roofs are wood framed. The roof above shipping containers needs only 7 ¼” cavities for fiberglass insulation. The 2” foam insulation is sprayed over the steel roof of each shipping

container. This solution takes care of cavity problems due to corrugation of steel. For the roof hanging above the area of the fellowship hall, it doesn't have any spray foam insulation. It requires 12-1/4" wide cavities to reach the optimal insulation. It rests on the wood-framing system that is attached to structural concrete. Figure 24 shows the detail of the framing system of the roofs. Figure 25 shows a 2D section view of the roof that is above the fellowship hall. Figure 26 shows the 2D section view of the roof that is above shipping containers.

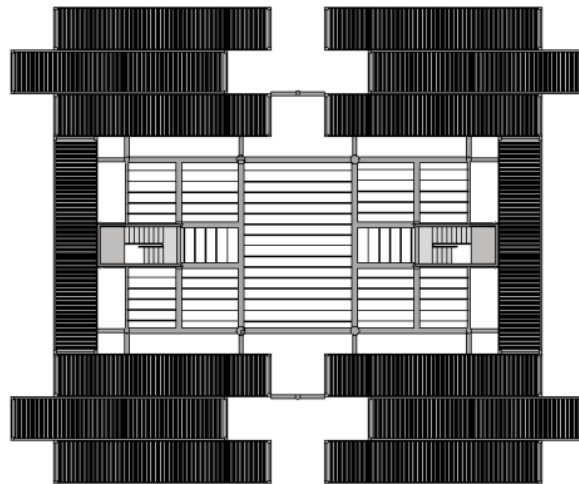

Figure 24. *Wood Framing on Structural Concrete as a Roof Support.*

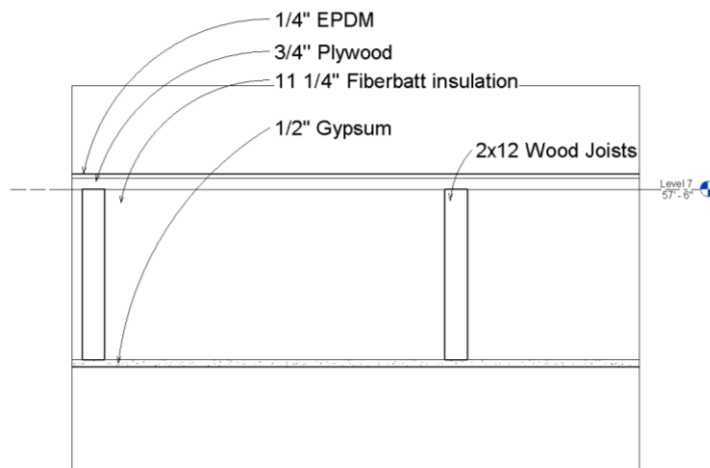

Figure 25. *Roof above Fellowship Hall Design.*

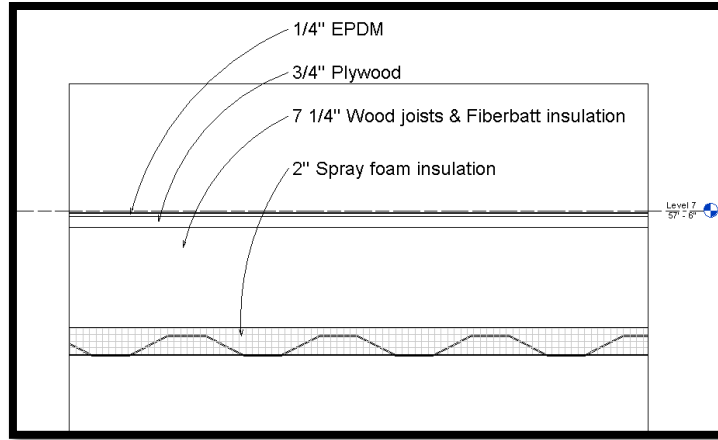

Figure 26. *Roof above Shipping Containers Design.*

Building Foundation and Load Bearing Model

There are three widely used types of foundation for the shipping container buildings: (1) shallow foundation, (2) deep foundation, and (3) pile foundation (Giriunas, et al., 2012). Geotechnical investigation is needed in order to design the foundation that fits the specific soil and location for a container building. This research uses pile foundation type for the student residence. All the load-bearing columns rest on the concrete caps at the tops of the piles (as shown in Figure 27 and 28). The steel piles have the dimensions of 16'' diameter and 20' depth. The concrete caps have the dimensions of 39''x39''x35''. All together there are 70 steel piles and 2,156 CF of concrete caps used for the foundation of the residence.

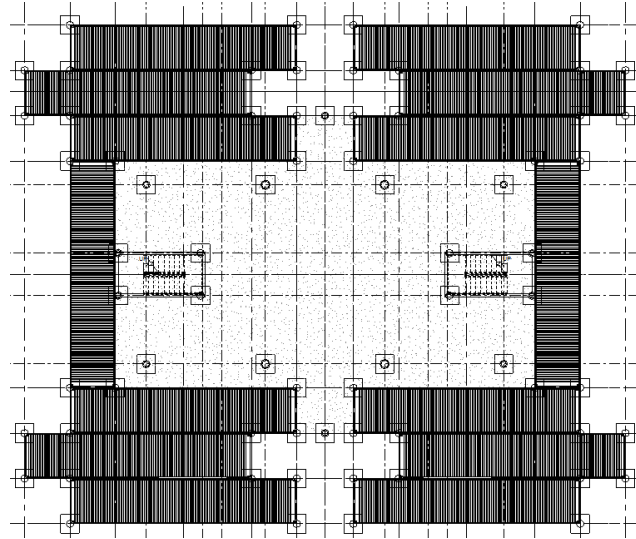

Figure 27. *Foundation Design (Plan View).*

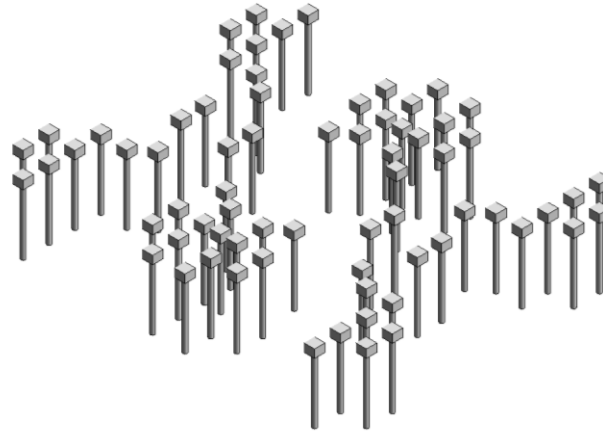

Figure 28. *Foundation Design (3D View).*

When working on the structural design, the author considered the following loads according to the US Department of Housing and Urban Development (n.d.): (1) dead load (DL) and (2) life load (LL). The corner posts of the shipping containers are able to withstand slightly above 210 kip (Giriunas, et al., 2012). However, the load-bearing capacity of shipping containers changes when some structural modifications are applied. The author decided minimize removal of the end walls and door assemblies of the containers, because that type of modification leads to the weakest load-bearing

structures of containers (Giriunas, et al., 2012). In the BIM model of this research, the largest modification is a 12'x8'-5" opening along a side wall of a container. Another modification is the complete removal of both side walls from a container. Results showed that the load-bearing capacity of containers with that type of modification is not different from the load-bearing capacity of non-modified containers (Giriunas, et al., 2012, pp. 88). The load-bearing capacity after modification is around 950 kN, or slightly above 210kip.

Table 11 shows that in the BIM model, the corner post of each container of an apartment on the 5th level is subject to 8.5 kip structural load, 4th level is subject to 13.7 kip and so on till 34.5 kip loads on foundation pile. The calculation has two basic assumptions as follows: (1) all loads are equally distributed on the 12 corner posts of one apartment; (2) all the possible DL and LL are simply aggregated. According to the US Department of Housing and Urban Development, however, the total load of the post can be calculated by following formula:

$$Load = DL + LL + 0.3L_r$$

In the above formula, L_r is the maximum life load on the roof anticipated from construction or maintenance. Using that formula, the total load applied to one corner post of the 5th floor is 7.2 kip, and each of 12 corners on the 1st level is subject to 28 kip loads. The maximum load per foundation pile is calculated as 33 kip if using the recommendation of the US Department of Housing and Urban Development, and 34.5 kip if using simple aggregation technique. Therefore, the residence design using shipping containers as structural components is appropriate for a 6-level building.

Table 10. *Dead and Life Load Table* (US Department of Housing and Urban Development, n.d.).

Component	Description	DL in psf	Description	LL in psf
Roof	Light-frame wood roof with wood structural panel sheathing and 1/2-inch gypsum board ceiling (2 psf) with asphalt shingle roofing (3 psf)	16	Flat to 4:12 slope	20
Roof	-with tar and gravel	18		
Floor	Light-frame 2x12 wood floor with 3/4-inch wood structural panel sheathing and 1/2-inch gypsum board ceiling (without 1/2-inch gypsum board, subtract 2 psf from all values) with carpet, vinyl, or similar floor covering	10	Bedroom areas	30
Floor	-with wood flooring	12	Other areas	40
Floor	-with ceramic tile	15		
Wall	Light-frame 2x4 wood wall with 1/2-inch wood structural panel sheathing and 1/2-inch gypsum board finish (for 2x6, add 1 psf to all values)	6		
Wall	-with vinyl or aluminum siding	7		
Wall	Interior partition walls (2x4 with 1/2-inch gypsum board applied to both sides)	6		

Table 11. Load Applied per Load Bearing Components.

Component	Area	DL (psf)	LL (psf)	Roof	Level 6	Level 5	Level 4	Level 3	Level 2	Level 1	Load per pile
Roof	1,104	16	20	39,744							
Bathrooms	136	15	40		7,480	7,480	7,480	7,480	7,480	7,480	
Apartment hall	112		40		4,480	4,480	4,480	4,480	4,480	4,480	
Bedrooms	640		30		19,200	19,200	19,200	19,200	19,200	19,200	
Kitchen	160		30		4,800	4,800	4,800	4,800	4,800	4,800	
Walls (Insulated)	78	6			468	468	468	468	468	468	
40' Container	960	27			25,935	25,935	25,935	25,935	25,935	25,935	
Total load per area				39,744	62,363	62,363	62,363	62,363	62,363	62,363	
Load per corner post				3,312	5,197	5,197	5,197	5,197	5,197	5,197	
Cumulative load				-	3,312	8,509	13,706	18,903	24,100	29,297	34,494
Load per corner post by USDHUD				2,024	5,197	5,197	5,197	5,197	5,197	5,197	
Cumulative load by USDHUD					2,024	7,221	12,418	17,615	22,812	28,009	33,206

Gym, Fellowship Hall, and Studying Rooms Design

The minimalistic design is used for the residence's recreational area. It is located on the first level of the residence. The area of the gym is 2,758 ft² as shown in Figure 29. The budget figure of the fitness equipment in the gym is discussed in the Chapter V of this research.

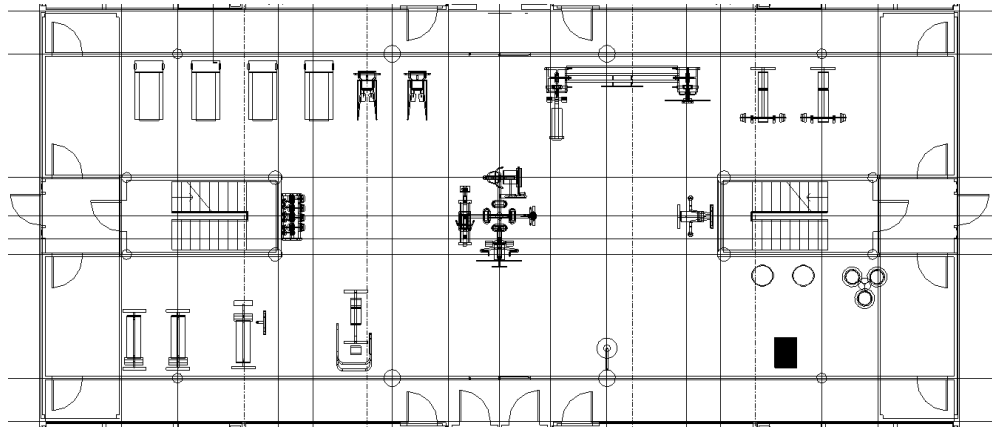

Figure 29. *Recreational Area (Plan View).*

The fellowship hall of the residence has several sets of table tennis and billiard tables. The fellowship hall has wood finishes as shown in Figure 30. The area of the fellowship hall is 3,535 ft² and is presented in Figure 31.

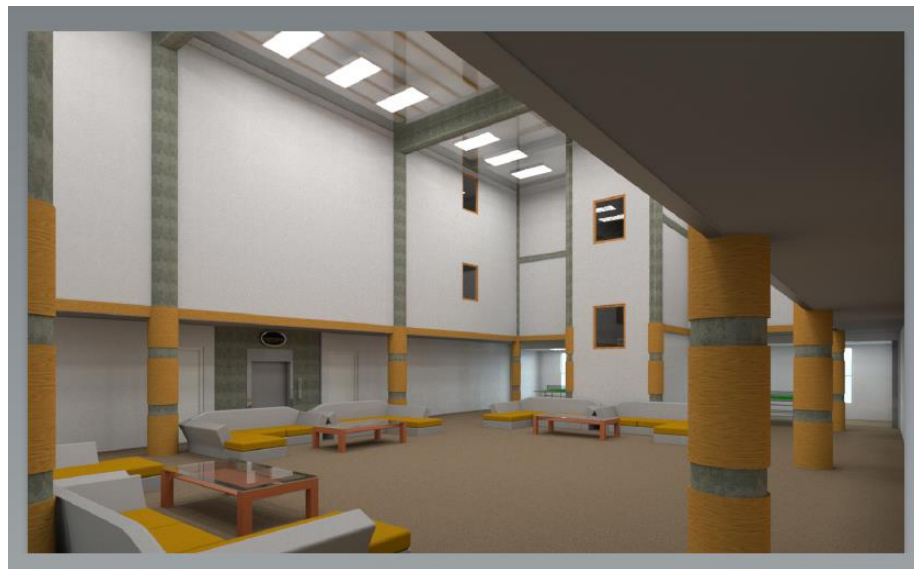

Figure 30. *Fellowship Hall (Render).*

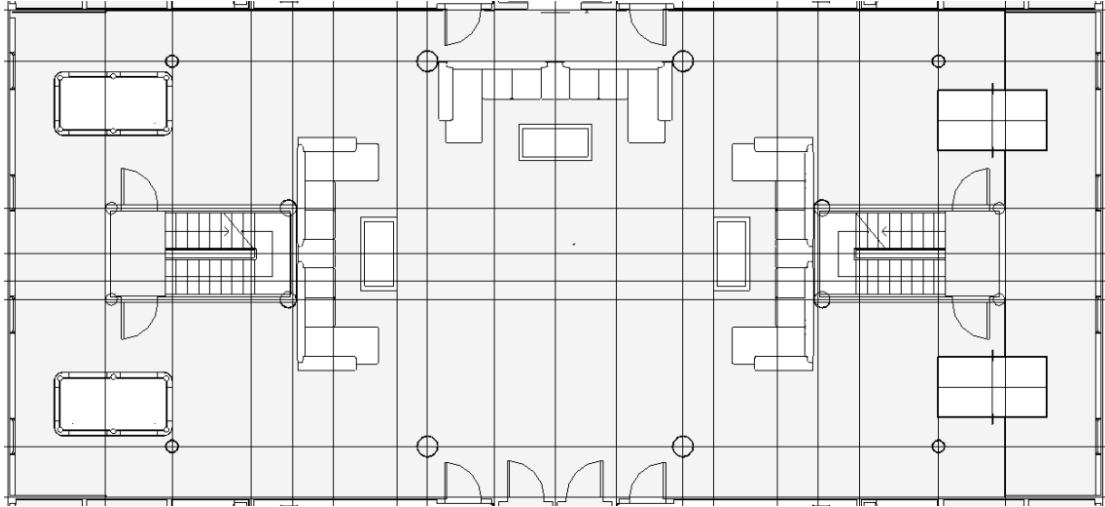

Figure 31. *Fellowship Hall (Plan View).*

The studying rooms are placed in the 40' HC shipping containers as shown in Figure 32. Each studying room is 70 ft². It has a large window opening for a significant amount of natural light. There are a table and a couple of chairs in each studying room. Carpet is installed above the plywood floors of shipping containers. Drywall finishes are applied on walls and ceilings as shown in Figure 33.

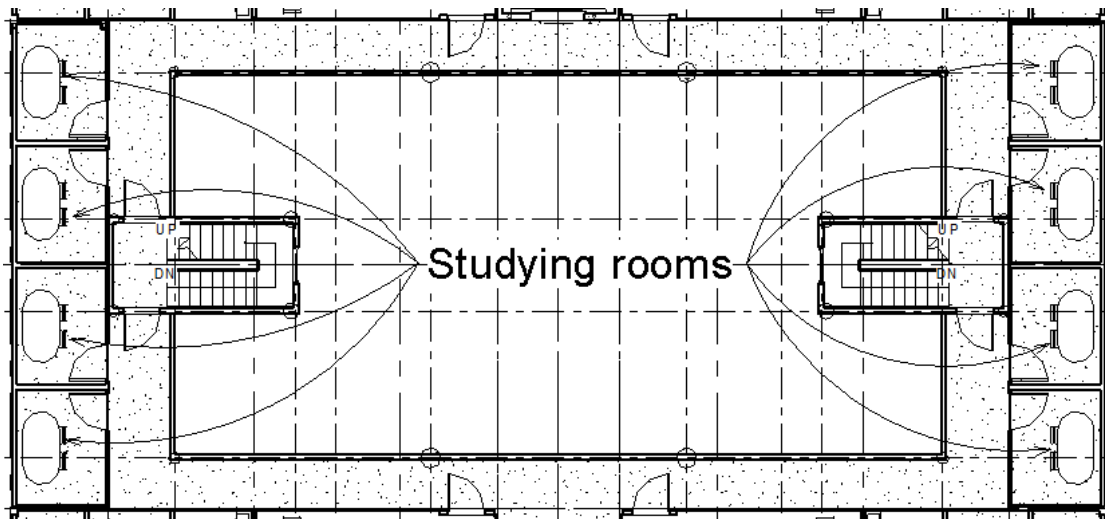

Figure 32. *Studying Rooms (Plan View).*



Figure 33. *Studying Rooms (Render).*

Model for Economic Analysis

In this section of the current research the author describes an approach to extrapolate life cycle financial data of the alternative residence and 3 case studies for comparison analysis.

First step is to make some assumptions about residences operation cycle. The first assumption is that all 4 cases are financed through a mortgage with 20% down payment and 6% annual rate. Next assumption is that project developers desire to earn 11% return on down payment they invest. Vacancy and annual maintenance expenses other than energy cost assumed to be 5% and 36% respectively (Table 12). The last assumption is that residence will be occupied all 12 month of the year.

Table 12. *Assumptions for Economic Analysis.*

Assumption	Rate
Initial investment (down payment)	20%
Loan interest rate (annual)	6%
Return on Investment	11%
Vacancy	5%
Annual expenses	36%

The next step is to derive monthly rent per bed. Rent per bed tightened directly to Construction Cost per Bed ratio. Table 13 shows rent derivation procedure. After derivation of monthly rental prices it is possible to perform economic comparison of the residences. As it was briefly described in Chapter III, Section Materials, Tools, Software and Data of the current research the author uses Modified Accelerated Cost Recovery System (Newnan, et al., 2004), S&P Capita IQ statistics and Consumer Price Index in order to come up with project life cycle period, discount rate and inflation rate respectively. Though aforementioned tools provide some fixed numbers (Table 14) it is rational to include some randomness in the life cycle extrapolation of them. The author describes this procedure in details in the Section Energy Consumption Estimates of the current research.

Table 13. Derivation of Monthly Rental Price per Bed.

Line number	Item	The Lodge	Covington Apartments	Crosswalk Commons
1	Number of Beds	307	56	120
2	\$ Constr./bed	\$43,885	\$53,658	\$51,672
3	Total Constr. Cost (Line1 * Line2) (Table 4)	\$13,472,695	\$3,004,848	\$6,200,640
4	Down payment 20% (Line3 * 20%)	\$2,694,539	\$600,970	\$1,240,128
5	Annual Interest + Principle Payment at 6%	\$795,588	\$177,442	\$366,160
6	ROI on down payment at 11%	\$296,399	\$66,107	\$136,414
7	Annual expenses 36% ([Line5 + Line6] / 64% * 36%)	\$614,243	\$136,996	\$282,698
8	Vacancy 5% ([Line5+Line6+Line7] / 95% * 5%)	\$89,802	\$20,029	\$41,330
9	Energy cost (Table 4)	\$120,000	\$23,000	\$45,000
10	Annual Revenue (Line5 + Line6 + Line7 + Line8 + Line9)	\$1,916,032	\$423,573	\$871,601
11	Monthly Rent Per Bed (Line10 / Line1 / 12 month)	\$520	\$630	\$605

Table 14. *Other Components of Economic Analysis.*

Tool	Value
MACRS	28 years
S&P Capita IQ	8.33%
CPI	2.79%

Further based on aforementioned in Tables 12, 13 and 14 numbers the author develops annual cash flow models based on 28 years of projects' life cycle. Cash flow models include revenue and expenses adjusted by inflation, further cash flow figures are discounted and based on that discounted figures the author gets NPV, IRR, PI and DPM values (see Chapter III, Section Economic Analyses of the Residence). Further those values are subjected to the Monte Carlo data simulation process to get more realistic averages and standard deviations that are used for the economic comparison analysis of the alternative student residence with three factual student residences.

CHAPTER V

DATA, ANALYSIS AND CONCLUSION

Budget Estimates

The author used RS Means Building Construction Cost Data 2014 edition to calculate the budget estimates of the project. This tool is widely used by construction companies and education institutions as a reliable source of construction cost data. The RS Means publishes wide varieties of construction data. In this research, the construction is in the category of commercial projects and large multi-family housing (RS Means, 2013). The data item of RS Means provides information about performing crew, its productivity, materials used, labor and equipment cost.

The data set in RS Means provides project location factor and time factor. In this research, the author used 3 case studies for comparison analysis. Two case studies were built mostly during 2012 and one was built in 2011. However, the budget estimates of the current student residence will be calculated using 2014 data. Therefore, the data in the case studies needs to be adjusted by the time index and the national average index in order to make it equivalent to the current budget estimates. Tables 3 in Chapter IV show the adjustments.

Based on the data provided by RS Means (2013), Table 15 shows the budget estimate for the student residence. RS Means (2013) recommends including 10% of

General Contractor (GM) markup and 5% of contingency fund. Proposed in the Table 15 budget estimate includes a division for other expenses that accounts for 5% of gross project cost estimate. This division is included to reflect some omitted expenses like landscaping, removal of harmful chemicals of shipping containers floors, fluctuations in containers delivery prices etc. The calculation of the contingency fund also considered the GM markup. Appendix D has more detailed tables of the budget estimate.

There are 70 piles, 2 157 CF of concrete caps, 40 480 CF of excavation and 1 pile set up included in foundation cost estimate (for details see Table D1). Table 15 shows that the foundation accounts 3.8% of the total budget estimate. There are two superstructures integrated in the structural design of the residence. The first is composed of shipping containers secured to each other (for details see Table D2). The second is made of reinforced concrete and wood elements (see Table D3). The overall share of the superstructure system of the model in the total budget is 11.5%. Although the stairwells can be considered as the structural components of the building, the author decided to show them as separate budget figures (see Table D4). The building superstructure plus the stairwells are 13.9% of the budget estimate.

Stairwells are enclosed with 2-hour fire-rated interior walls on 2x4 wood studs. The RS means (2013) doesn't provide the estimate data for that type of walls. The author used the cost data of partition wall fished with a drywall on both sides for the stairwell walls. Drywall component was subtracted from the cost and recalculated separately with the consideration of 2-hour fire rating. The design includes monolithic concrete stairs and 3'' concrete on metal deck for landings. One stairwell is extended to the roof. The

additional walls that rise above the roof are made of 2x4 wood stood with plywood sheeting and finished with brick vinyl.

The budget of the integrated common fellowship, recreational and studying areas makes 11.4% of the residence budget estimate. Table 15 shows the cost estimate for common areas including: (1) plumbing, HVAC, and electrical estimates, and (2) furniture and equipment cost estimates. RS Means (2013) provides cost for those systems per square footage of the residence. The plumbing cost of the common area assumed to be no more than the plumbing cost of the 2 apartments. Tables D5 and D6 have detailed discussion on the systems. Elevator cost estimate makes 2.3% of the budget.

The apartment's cost makes up 39.7% of the overall budget. The floors of the apartments on the first level are insulated with spray foam insulation, which makes up 0.6% of the budget. The cost of one apartment is \$56 114, all together there are 24 apartments in the residence that are able to accommodate 96 students. Tables 15, D7 and D8 have further discussion on the apartment costs.

Next component of the budget estimate is roofing. It is 2.2% of the total budget. Detailed roofing budget is shown in Table D9. Siding is another large component of the budget which is 13.0% of the total building cost. It significantly contributes to the exterior appearance of the building. Figure 34 shows the images of the exterior appearances of the designed building. Table D10 shows that the siding mainly made of two components: (1) thin brick veneer and (2) lightweight natural stone.



Figure 34. 3D View of the Residence with Siding

Table 15. Complete Budget Estimate of the Student Residence.

Item	Cost estimate Based on RS Means Data	General Contractor's markup 10%	Total per Item	Share in total budget
Foundation cost estimate	\$129,948	\$12,995	\$142,943	3.8%
Shipping containers superstructure cost estimate	\$248,005	\$24,801	\$272,806	7.3%
Conventional superstructure cost estimate	\$140,115	\$14,012	\$154,127	4.1%
Stairwells cost estimate	\$83,898	\$8,390	\$92,288	2.5%
Common shared areas cost estimates including:	\$387,282	\$38,728	\$426,010	11.4%
Plumbing, HVAC, Electrical, Mechanical	\$101,712	\$10,171	\$111,883	3.0%
Furniture & equipment cost estimate	\$69,892	\$6,989	\$76,881	2.1%
Elevator cost estimate	\$79,400	\$7,940	\$87,340	2.3%
Apartment's cost estimate including:	\$1,346,736	\$134,674	\$1,481,410	39.7%
Plumbing, HVAC, Electrical, Mechanical	\$484,460	\$48,446	\$532,906	14.3%
Furniture & appliances	\$198,487	\$19,849	\$218,336	5.9%
Exterior walls spray insulation	\$15,094	\$1,509	\$16,603	0.4%
Exterior floors spray insulation cost estimate	\$19,560	\$1,956	\$21,516	0.6%
Roofing cost estimate	\$73,695	\$7,369	\$81,064	2.2%
Siding cost estimate	\$439,574	\$43,957	\$483,531	13.0%
Parking cost estimate	\$42,106	\$4,211	\$46,316	1.2%
Fire suppression system cost estimate	\$89,710	\$8,971	\$98,681	2.6%
Gross project cost estimate	\$3,080,028	\$308,003	\$3,388,031	90.9%
Other construction expenses 5%			\$169,402	4.5%
Contingency fund 5%			\$169,402	4.5%
Total project cost estimate			\$3,726,834	100.0%

Last two components of the budget are parking and fire suspension systems. Although all three case studies don't include the cost of land, their lump sum budgets include overall parking cost estimates, therefore it also include in the current research. Parking is 1.2% of the total budget. The residence's parking includes 50 parking spots which exceeds minimum parking requirements by 2 spots. For the fire suspension system, it is approximately 3% of the budget's estimate. The number shown in the Table 15 constitutes 2.6% of the total budget.

Energy Consumption Estimates

In this research, the author used GBS energy simulation tool in order to obtain the annual figure for the new residence's annual energy usage. In order to check whether GBS delivers reliable results, energy simulation on the three case studies were conducted. For that reason the author modeled the 3 buildings. The 3 models of case studies were made using Revit Architecture. The author kept similar external shapes of the buildings and their internal areas. Figures 35, 36 and 37 show the details. Energy simulation test were made for the two building types: (1) dormitory building type, and (2) multifamily building type (Table 16).

Table 16. *Case Studies' Energy Simulation Results.*

Residences	Factual	Simulated as a dorm	Differential index	Simulated as a multi-family	Differential index
The Lodge on Willow	\$120,000	\$171,503	30.0%	\$116,544	-3.0%
Covington Apartments	\$23,000	\$50,300	54.3%	\$32,659	29.6%
Crosswalk Commons	\$45,000	\$65,445	31.2%	\$45,448	1.0%

Simulation results show that it would be misleading to use dormitory building type while running simulation on alternative residence. Table 16 shows that selecting that building type makes the difference when study actual annual energy consumption of the buildings.

Therefore, the author decided to use multifamily type of building while running energy simulation for the residence designed. Another problem is that the Covington Apartments energy simulations results exceed factual energy cost by 29.6% even when multifamily type of building is selected. There is no certainty where this difference comes from. However some assumptions can be made: (1) residence has the largest square footage per tenant; it means that there are less energy consuming elements like light fixtures or kitchen appliances per square foot of residence, (2) the residence is mostly rented by American students. They don't live in their apartments during the summer. During summer time the largest amount of electricity is used for cooling. However, if no one lives in the apartments, the HVAC systems are inactive. It is impossible to include seasonality of building usage into GBS. Therefore the simulation results returned are based on the whole annual building usage. However, excluding June, July and August, the energy costs from total energy cost generates a figure of \$24 582 which differentiates only by 6.88% from \$23 000 of factual energy cost.

Table 17. *Energy Simulation Results of Covington Apartments.*

Month	Energy cost	
Jan	\$3,266	\$3,266
Feb	\$2,807	\$2,807
Mar	\$2,771	\$2,771
Apr	\$2,589	\$2,589
May	\$2,730	\$2,730
Jun	\$2,655	
Jul	\$2,726	
Aug	\$2,696	
Sep	\$2,482	\$2,482
Oct	\$2,486	\$2,486
Nov	\$2,470	\$2,470
Dec	\$2,981	\$2,981
Total	\$32,659	\$24,582

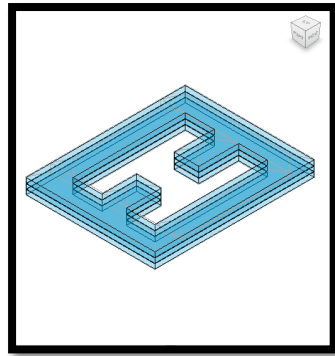

Figure 35. *The Lodge on Willow Energy Model.*

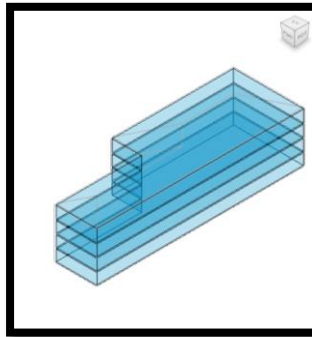

Figure 36. *Covington Apartments Energy Model.*

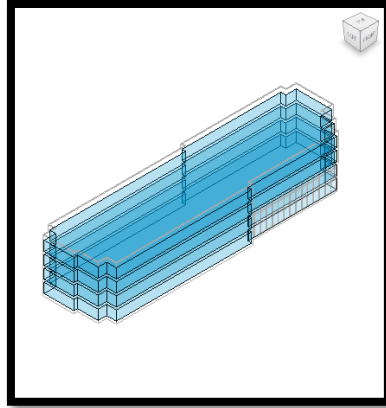

Figure 37. *Crosswalk Commons Energy Model.*

Table 18 shows the results of energy simulation for the building designed. This data is used as an element of financial and cash flow models described in the Chapter IV of the current research.

Table 18. *Alternative Student Residence Energy Simulation Results.*

Residences	Simulated as a dorm	Simulated as a multi-family
Alternative residence	\$44,757	\$31,636

Construction and Energy Data Analysis

The Alternative Residence has largest Shared Area per Bed coefficient which exceeds the one of the Crosswalk Commons by almost 40%. Using shipping containers as structural components of a building is very efficient.

For the initial energy simulations, GBS application assumes R-20 value for roof, R-13+7.5 value for metal frame walls, R-20 value for wood frame floors. Those R values do not meet thermal resistance requirements specified in the research. However, it is shown in the Table 16 that under multifamily building type GBS returns results that are fairly close to the actual energy cost figures of case studies. This shows that those simulation results can be trusted.

In the research, the author developed a design for exterior components of the building that meets the basic requirements for thermal resistance. It implies that exceeding energy consumption should not be expected. Although that type of insulation could be slightly expensive, the cost of the project as a whole shows that it is possible to build that type of buildings with reduced amount of financing comparing to conventional construction. GBS energy simulation reveals that due to fairly small apartment volumes the Energy per Bed coefficient of the new residence is the smallest in the group (Table 19).

Table 19. *Comparison Analysis of General Data of Alternative Residence.*

Residence name	Construction Budget (million \$)	Square footage (SF)	Living area (SF)	Number of Beds	Number of floors
The Lodge on Willow	\$13.47	160,000	150,000	307	3
Covington Apartments	\$3.00	32,000	26,500	56	5
Crosswalk Commons	\$6.20	44,000	31,000	120	4
Alternative Residence	\$3.73	38,572	24,210	96	6
Residence name	Shared Area/bed (SF)	Budget/SF	Budget/bed	Annual energy cost	Energy cost/bed
The Lodge on Willow	32.57	\$84.2	\$43,885	\$120,000	\$390.88
Covington Apartments	98.21	\$93.9	\$53,658	\$23,000	\$410.71
Crosswalk Commons	108.33	\$140.9	\$51,672	\$45,000	\$375.00
Alternative Residence	149.60	\$96.6	\$38,821	\$31,636	\$329.54

Financial Data

The identical concept to the one discussed in Chapter IV is used to identify monthly rental cost per bed of the alternative student residence. Cost figures of the project budget and energy consumption are included in the following derivation of Table 20.

Table 20. *Derivation of Monthly Rental Price per Bed with Alternative Student Residence Included.*

Item	Alternative residence	The Lodge	Covington Apartments	Crosswalk Commons
Number of Beds	96	307	56	120
\$ Constr./bed	\$38,821	\$43,885	\$53,658	\$51,672
Total Constr. Cost	\$3,726,834	\$13,472,695	\$3,004,848	\$6,200,640
Down payment 20%	\$745,367	\$2,694,539	\$600,970	\$1,240,128
Annual Interest + Principle Payment at 6%	\$220,077	\$795,588	\$177,442	\$366,160
ROI at 11%	\$81,990	\$296,399	\$66,107	\$136,414
Annual expenses 36%	\$169,913	\$614,243	\$136,996	\$282,698
Vacancy 5%	\$24,841	\$89,802	\$20,029	\$41,330
Energy cost	\$31,636	\$120,000	\$23,000	\$45,000
Annual Revenue	\$528,457	\$1,916,032	\$423,573	\$871,601
Monthly Rent Per Bed	\$459	\$520	\$630	\$605

The next step is to derive realistic procedure for extrapolated revenue and expenses from Table 20, taking into consideration the inflation rates. In accordance with US Department of Labor Bureau of Labor Statistic (2015), the CPI of last 30 years reveals 2.79% average and 1.14% standard deviation for years 1985 - 2014. Assuming that inflation falls under the rules of normal distribution as shown in Figure 38, the authors generated the 28 years of projection of future inflation values using MS Excel application. Figure E1 shows the details of the calculation. The “NORMINV ()” and “RAND ()” functions of MS Excel are used to calculate the data in Figure E1. For example, NORMINV(RAND(), 2.79%, 1.14%) returns the value “X” which is a normal

randomized variable with the mean of 2.79% and the standard deviation of 1.14%. “X” is selected at random using “RAND ()” function of Excel, which returns any number between 0 and 1 every time any changes made to the Excel file. All the 28 extrapolated inflation values are generated under the rules of normal distribution. The cost of capital for the next 28 years is assumed to be a fixed number of 8.33% (Damodaran, 2015).

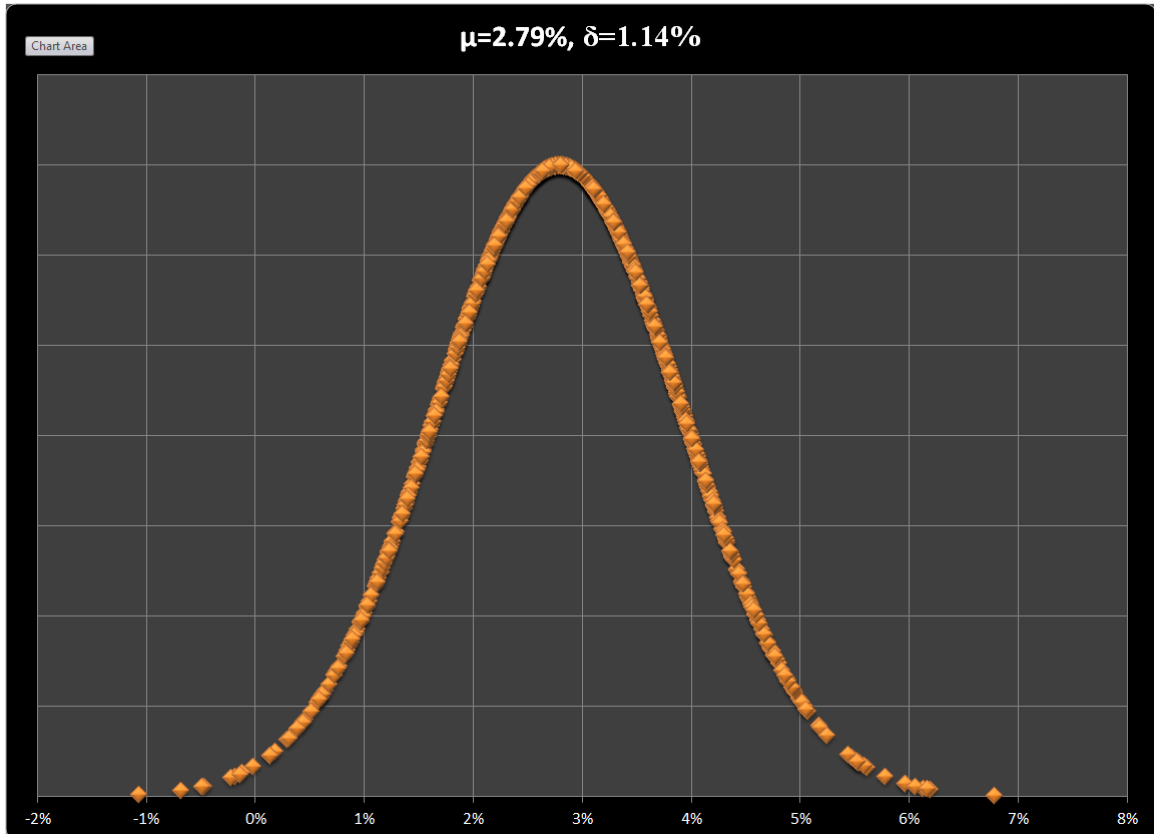

Figure 38. *Normally Distributed Inflation.*

The cash flows of the 4 case models are projected for 28 years forward. The returned values of NPV, IRR, PI, and DPM of the 4 projects are used in the Monte Carlo simulations with 500 observations. The averages of the simulated values of NPV, IRR, PI, and DPM are used to draw conclusions.

Economic Analysis

Initial Monte Carlo simulations reveal that under the same market conditions, the Lodge on Willow project has the best performance. However the Lodge on Willow project is the largest among all the selected ones. Its investment volume exceeds the volume of the proposed residence by 262%, exceeds the volume of Covington Apartments by 348%, and exceeds the volume of Crosswalk Commons by 117%. The largest NPV value for the Lodge on Willow project is because of the investment volume. Under certain market conditions, large projects are efficient to generate capital. But usually the off-campus locations are limited at the availability of new construction areas. It is difficult to start such a massive project as the Lodge on Willow.

The IRR values are below the identified Cost of Capital, which is 8.33% as shown in Table 21. This means that under specified condition none of the projects has enough profitability to owners. To fix this problem, project developers need to achieve higher ROI. The sensitivity analysis in Table 22 shows that as ROI requirements increase, the gap between the rental price of the proposed project and the rental prices of the projects in the case studies also increase. It means that the proposed project has better potential in market competition.

Table 21. Monte Carlo Simulation Results #1.

Analysis Parameter	New residence	The Lodge	Covington Apartments	Crosswalk Commons
NVP Mean	\$760,732	\$2,758,114	\$611,211	\$1,268,439
NVP Standard Deviation	\$38,678	\$136,155	\$29,602	\$59,226
NVP MAX	\$905,346	\$3,236,696	\$711,556	\$1,454,340
NVP MIN	\$619,349	\$2,366,568	\$523,449	\$1,089,687
IRR Mean	7.86%	7.88%	7.84%	7.88%
IRR Standard Deviation	0.24%	0.25%	0.23%	0.23%
IRR MAX	8.65%	8.71%	8.50%	8.50%
IRR MIN	6.97%	7.20%	7.11%	7.18%
PI Mean	2.02	2.02	2.02	2.02
PI Standard Deviation	0.05	0.05	0.05	0.05
PI MAX	2.21	2.20	2.18	2.17
PI MIN	1.83	1.88	1.87	1.88
DPM Mean	10.78	10.75	10.79	10.76
DPM Standard Deviation	0.23	0.24	0.23	0.22
DPM MAX	11.61	11.42	11.61	11.42
DPM MIN	10.08	9.95	10.16	10.17
Note: ROI - 11%				

Table 22. Sensitivity Analysis for Associated Increase in Return of Investments.

Monthly Rent Per Bed at:	Alternative Residence	The Lodge	Covington Apartments	Crosswalk Commons
ROI - 11%	\$459	\$520	\$630	\$605
ROI - 15%	\$501	\$568	\$689	\$662
ROI - 20%	\$555	\$628	\$763	\$733
ROI - 25%	\$608	\$689	\$836	\$804
Difference in cost at:				
ROI - 11%		\$61	\$172	\$147
ROI - 15%		\$67	\$188	\$161
ROI - 20%		\$74	\$208	\$178
ROI - 25%		\$81	\$229	\$196
Note: Rental cost of Alternative Residence is used as a base for calculating difference in minimum required rental cost for other apartments.				

The second Monte Carlo simulation conducted under following assumption: if more residence buildings around college campuses using innovative materials, that would

drive the average rental price down. The simulation analysis revealed that the breakeven of ROI requirement is slightly above 11%. Therefore developers would require at least 12% ROI. The minimum required rental price is \$469 per bed per month. Table 23 shows the results of NPV analysis.

Table 23. Monte Carlo Simulation Results #2.

Analysis Parameter	Alternative residence (AR)	The Lodge	Covington Apartments	Crosswalk Commons
NVP Mean	\$913,615	(\$32,971)	(\$967,754)	(\$1,599,674)
NVP Standard Deviation	\$42,012	\$66,891	\$9,060	\$8,415
NVP MAX	\$1,076,374	\$188,798	(\$944,771)	(\$1,575,521)
NVP MIN	\$805,978	(\$237,518)	(\$998,450)	(\$1,631,324)
IRR (AR) - 9.29%				
PI (AR) - 2.23				
DPM (AR) - 9.50				

Recommendations for Future Research and Conclusion

Results shown in the Table 23 reveal that conventional buildings don't have the same economic competitiveness with the innovative building (See Appendix E and F for details). It doesn't mean that conventional student residences shouldn't be built. The owners of conventional buildings won't necessarily have financial losses if innovative residences gain more market.

One recommendation for future research is to study customer preferences. It is important to know whether customers would prefer to live in provided innovative housing. The research reveals that from economical point of view the idea of integrating shipping containers as structural components of buildings is practical and sound, but it won't help developers earn profit if students prefer to live in conventional housing. Further research recommendations are: (1) developing detailed design and budget

estimates of the project for such components as plumbing, electrical, HVAC and fire suspension systems. (2) Though it was mentioned that usage of shipping containers can allow for faster project delivery, it is still a question how long will it take to build the residence developed in the research. To answer this question it would be rational to develop detailed project schedules and integrate them into BIM 4D software. (3) Develop methodologies of prefabricated construction. Prefabrication will provide a way for more efficient project delivery in terms of time and money. Theoretically modified, insulated, and finished containers with integrated electrical, plumbing and duct work can be delivered on project site and assembled together.

The analysis show that shipping containers could be used to replace the traditional structural components and construction materials for student housing purposes. Energy simulation doesn't reveal any significant increases in energy consumption of the building. Residence design methodology shows that it is absolutely feasible to build mid-rise buildings integrating shipping containers as a structural component. Project cost estimation supports the idea that the usage of shipping containers can significantly reduce construction cost.

REFERENCES

- Andjelković, B. V., Stojanović, B. V., Stojiljković, M. M., Janevskić, J. N., & Stojanović, M. B. (2012). Thermal mass impact on energy performance of a low, medium, and heavy mass building in Belgrade. *Thermal Science*, 16(2), S447.
- Argon, J. (2008). Annual Residence Hall Construction Report. *American School and University*, 20, 6. Retrieved December 14, 2014, from http://asumag.com/Construction/res_halls/residence-hall-construction-report-200906?page=6
- Autodesk. (n.d.). Green building studio user guide - using Green Building Studio with Revit Architecture and Revit MEP. Retrieved December 15, 2014 from http://images.autodesk.com/adsk/files/using_green_building_studio_with__revit.pdf
- Bolotin, S. A., Gurinov, A. I., Dadar, A. H., & Oolakay, Z. H. (2013). An energy efficiency evaluation of architectural and construction solutions of an initial design stage in Autodesk REVIT Architecture. (English). *Magazine of Civil Engineering*, (8), 64-91.
- Cooper, J., Kilmer, J., Wands, B. (2003). *Stacking shipping containers on land for an off-axis detector*. Fermi National Accelerator Laboratory, Batavia, IL 60510. Retrieved December 14, 2014, from <http://nova-docdb.fnal.gov/0003/000308/001/nova0008.pdf>
- Crepeau, R. L. (2009) Shipping Container Drawings. Retrieved February 2, 2015 from <http://www.arktist.com/ArkPhoenix/ShippingContainerDwgs/containerdwgs.html>
- Crosswalk Project, Inc. (2015). Crosswalk commons. Retrieved March 23, 2015 from <http://www.crosswalkcommons.com/about-international-living-learning-community>
- De Coster, D. A., & Mable, P. (1974). *Student development and education in college residence halls*, David A. De Coster and Phyllis Mable, editors. Washington, American College Personnel Association [c1974].
- Damodaran, A. (2015). Cost of Capital by Sector. Retrieved June 3, 2015 from: http://pages.stern.nyu.edu/~adamodar/New_Home_Page/datafile/wacc.html.htm
- Drummer, R. (2013, February 13). Boom in student housing construction stokes concerns of oversupply. Retrieved January 9, 2015 from <http://www.costar.com/News/Article/Boom-In-Student-Housing-Construction-Stokes-Concerns-of-Oversupply/145715>
- Edwards, B., Hyett, P. (2002). *Rough guide to sustainability*, London: RIBA.
- Energy.gov. (2015, January 23). Types of insulation. Retrieved January 29, 2015 from <http://energy.gov/energysaver/articles/types-insulation>
- Estes, H. M. (2011). Economic analysis of energy retrofit of buildings. (Unpublished thesis). The University of Alabama, Tuscaloosa Alabama.

- First Site. (n.d.). Uptown North. Retrieved January 9, 2015 from <http://www.firstsiteapartments.com/on-campus/apartment-listings/bedrooms/3/property/uptown-north>
- Frederiksen, C. F. (1979). Managing college and university housing. *Business Officer*, 12, 22-24.
- Frost, S. (2014). The disadvantages to staying in dorms. Retrieved January 11, 2015 from <http://education.seattlepi.com/disadvantages-staying-dorms-2614.html>
- Giriunas, K., Sezen, H., & Dupaix, R. B. (2012). Evaluation, modeling, and analysis of shipping container building structures. *Engineering Structures*, 43, 48-57. doi:10.1016/j.engstruct.2012.05.001
- Gooch, J. W. (2010). *Encyclopedic dictionary of polymers [electronic resource] / edited by Jan W. Gooch*. New York; London: Springer, 2010
- Granadeiro, V., Duarte, J., Correia, J., & Leal, V. (2013). Building envelope shape design in early stages of the design process: Integrating architectural design systems and energy simulation. *Automation in Construction*, 32, 196-209.
- Green Building Studio. (n.d.). Cloud-based energy analysis software. Retrieved December 15, 2014 from <http://www.autodesk.com/products/green-building-studio/overview>
- Guy, S. (2000). *A sociology of energy, buildings and the environment: constructing knowledge, designing practice*. Routledge.
- Hardeman, R., Gerrard, M. D., & Owe, G. (2011). Minnesota Teen Challenge follow - up study. Retrieved December, 2104 from <http://teenchallengeusa.com/about/studies>
- HEDD Engineered Design. (n.d.). Double ended twist locks. Retrieved April 7, 2015 from <http://www.cornercastings.com.au/double-ended-twist-locks/>
- Herr, R. (2011, April 12). 10 Facts about shipping containers. Retrieved January 12, 2015 from <http://containerauction.com/read-news/10-facts-about-shipping-containers>
- HL Design Group. (2010). Research for proposed guest house / hotel project. Research document on shipping container architecture. Retrieved December 14, 2014 from <http://www.slideshare.net/PB4000XL/shipping-container-architecture-research>
- ISU. (2015). Quick facts of Illinois State University. Office of Admissions. Retrieved January 9, 2015 from <http://admissions.illinoisstate.edu/freshman/about/facts.php>
- Keitsch, M. (2012). Sustainable architecture, design and housing. *Sustainable Development*, 20(3), 141-145.
- Kensek, K. M., & Noble, D. (2014). Building information modeling: BIM in current and future practice / [edited by] Karen M. Kensek, Douglas Noble. Hoboken, New Jersey: Wiley, [2014].
- Kreith, F., Goswami, D. (2007) Handbook of energy efficiency and renewable energy [Electronic Resource] / Edited by Frank Kreith, D. Yogi Goswami [e-book]. Boca Raton: CRC Press.
- Lucko, G. (2013). Supporting financial decision-making based on time value of money with singularity functions in cash flow models. *Construction Management & Economics*, 31(3), 238-253.
- Marsh, P. (2010). Sustaining technical efficiency and the socialized home: examining the social dimension within sustainable architecture and the home. *International Journal of Interdisciplinary Social Sciences*, 5(5), 287-298.

- Maxman, S. (1993). Shaking the Rafters. *Earthwatch*, 11.
- Merschbrock, C., Munkvold, B. (2012). A research review on building information modeling in construction-an area ripe for is research. *Communications of the Association for Information Systems*, 31, 207-228.
- Mohamad, K., Phillip, B., Gillian, M. (2009). Life-cycle assessment and the environmental impact of buildings: a review. *Sustainability [serial online]*. (3):674.
- Narayanan, M. (1985). Observability and the Payback Criterion. *Journal of Business*, 58(3), 309-323.
- Nassar, K. (2012). Assessing Building Information Modeling estimating techniques using data from the classroom. *Journal of Professional Issues in Engineering Education & Practice*, 138(3), 171-180.
- National Center for Education Statistics. (n.d.). Admission trends [Data file]. Retrieved December 16, 2014 from <http://nces.ed.gov/ipeds/datacenter>
- Newnan, D. G., Lavelle, J. P., & Eschenbach, T. (2004). Engineering economic analysis / Donald G. Newnan, Ted G. Eschenbach, Jerome P. Lavelle. New York: Oxford University Press, 2004.
- Park, C. S. (1997). Contemporary Engineering Economics, 2nd ed. Menlo Park: Addison-Wesley Longman, Inc.
- Professionals Corner. (n.d.). R-Value Table. Retrieved January 29, 2015 form <http://www.coloradoenergy.org/procorner/stuff/r-values.htm>
- Ranking Web of Universities. (2014, January). Countries arranged by Number of Universities in Top Ranks. Retrieved January 9, 2015 from <http://www.webometrics.info/en/node/54>
- Page, R. M., & O'Hegarty, M. (2006). Type of student residence as a factor in college students' alcohol consumption and social normative perceptions regarding alcohol use. *Journal of Child & Adolescent Substance Abuse*, 15(3), 15-31.
- Realtor.com. (n.d.). Rental rates for Normal Illinois. Retrieved January 10, 2015 from http://www.realtor.com/local/Normal_IL/rent-prices
- Riker, C. H., & DeCoster, A. D. (2008). The educational role in college student housing. *The journal of college and university student housing*, 35(2), 80-85.
- Residential Prescriptive Requirements. (2009) International Energy Conservation Code (IECC). Retrieved January 28, 2015 from <https://energycode.pnl.gov/EnergyCodeReqs/?state=Illinois>.
- Residential Shipping Container Primer. (n.d.) ISO shipping containers and building code requirements. Retrieved December 15, 2014 from <http://www.residentialshippingcontainerprimer.com/ISO%20Shipping%20Containers%20and%20Building%20Code%20Requirements>.
- Rodriguez, J. (n.d.). ADA Guidelines for Handicapped Bathrooms. Retrieved March 25, 2015 from <http://construction.about.com/od/Inspection/a/Ada-Regulations-For-Handicapped-Bathrooms.htm>
- RSMMeans building construction cost data 2014*. (2013). Norwell, MA : RSMMeans, 2013
- Russell, C. (2009). Energy Cost Control: How the Money Works, Internet Presentation to the U.S. Department of Energy Industrial Technologies Program.

- Sebastian, R. (2010). Integrated design and engineering using building information modelling: a pilot project of small-scale housing development in the Netherlands. *Architectural Engineering & Design Management*, 6(2), 103-110. doi:10.3763/aedm.2010.0116
- Shrestha, P. P., & Kulkarni, P. (2013). Factors influencing energy consumption of energy star and non-energy star homes. *Journal of Management in Engineering*, 29(3), 269-278.
- Sultanguzin, I., Isaev, M., & Kurzanov, S. (2010). Optimizing the production of coke, coal chemicals, and steel on the basis of environmental and energy criteria. *Metallurgist*, 54(9/10), 600-607. doi:10.1007/s11015-011-9346-1
- US Census. (2015). Population Demographics for Normal, Illinois in 2014 and 2015 [Data file]. Retrieved January 9, 2015 from <https://suburbanstats.org/population/illinois/how-many-people-live-in-normal>
- US Department of Housing and Urban Development. (n.d.) Design Loads for Residential Buildings. Retrieved March 26, 2015 from www.huduser.org/portal/home.html
- US Department of Labor Bureau of Labor Statistic. (2015). Consumer Price Index Data from 1913 to 2015. Retrieved June 2, 2015 from: <http://www.usinflationcalculator.com/inflation/consumer-price-index-and-annual-percent-changes-from-1913-to-2008/>
- Vanek, F., Albright, L. (2008). Energy Systems Engineering [Electronic Resource]: Evaluation and Implementation / Francis M. Vanek, Louis D. Albright [e-book]. New York: McGraw-Hill
- Wallace, J. A. (2012). The Philosophy of University Housing. *Journal Of College & University Student Housing*, 38/39(2/1), 94-99.
- Zuiderwyk, C. (2014, January 28). Average port container life span and wear and tear. Retrieved January 12, 2015 from <http://www.portcontainerservices.com.au/blog/2014/01/average-port-container-life-span-wear-tear/>

APPENDIX A
JUSTIFICATION OF THE STUDENT HOUSING
WITH COMMUNITY FELLOWSHIP
ELEMENTS

In order to help students to grow culturally, spiritually, and psychologically in community, the proposed student residence should have an administrative personnel. Hiring the paid management personnel would take care of the students' social and psychological development. But the method still has pitfalls. For example, it could not stop students from seeking opportunities for alcohol abuses. In addition, it has very limited function in help students with spiritual growth. A better solution could be a Christian administration. In Chapter IV, the author presented a case study of "Crosswalk Commons" student residence that had a Christian administration. The administration of "Crosswalk Commons" extended welcoming hands to residents through housing. The housing was specifically designed for international students (Crosswalk Project, Inc., 2015). With the support of Salt and Light Christian Fellowship the residence administration was able to guide students thought life issues and help them to understand other cultures and ways of life (Crosswalk Project, Inc., 2015).

It showed that the students under that type of leadership would most likely start seeking satisfaction in developing their spirituality instead of ruining their life through alcohol or drug abuse (Hardeman, et al., 2011). Wilder Research is an independent

evaluator, it conducted a research for “Teen Challenge” - the Christian drug and alcohol rehab centers (Hardeman, et al., 2011). They sampled and conducted one-year follow-up telephone interviews with “Teen Challenge” graduates (Hardeman, et al., 2011). Researchers found that 74% of graduates reported “no use of drug or alcohol in the 6 months prior to follow-up, while 62% of graduates reported no relapses since graduation nor use in the past 6 months” (Hardeman, et al., 2011). Those successful rates are significantly higher than the rates of non-faith based rehab centers. That shows the success of Christian leadership in helping young generation to make right decisions for their future. The Christian leadership could be trusted as a management method for student residence. The above data support the author’s decision to design a fellowship hall in the proposed project.

APPENDIX B

INTERVIEWS

Interview #1 (January 28, 2015)

Interviewer: Tofiq Mammadov - Graduate student at Department of Technology in Illinois State University

Interviewee: Andy Netzer - Licensed Managing Broker of Young America Realty, Inc. since 2013.

Andy was managing approximately 35 employees. He oversaw approximately 1600 living units - 3300 beds. He has experiences in construction project management and project development. The following is the questionnaire used in the interview.

Please complete the following questions to reflect your opinions as accurately as possible and to answer factual questions to the best of your knowledge.

1. Average rental price per person for old buildings (before 2008) \$509 (4BR)
2. Average rental price per person for new buildings (since January 2008) \$706
3. Average square footages of the following areas:
 - a. Bedroom: 100-150 ft² (new buildings targeting 150 ft²)
 - b. Living room and kitchen: 300-700 ft²
 - c. Bathrooms: 40-50 ft²

4. For the current rental apartments or houses, how many persons share the use of one bathroom?
 - a. Max-4 Min-0.89 for apartments/houses and for fraternities 5 per shower and 4 per toilet.
5. How many persons share the use of one kitchen?
 - a. Max-4 Min-1 (On old houses, could be max of 10-12)
6. What can you say about the occupancy of the apartments with max amount of persons per bathroom and max amount of persons per kitchen?
 - a. There weren't any problems with high amount of people per kitchen, but as number of people per bathroom grows the occupancy decreases (The market has shifted away from demand of these types of units. They are harder to rent and demand lower rents).
7. How do you think rental price changes as the ratio of persons per bathroom changes?
 - a. There is an incredibly strong inverse correlation (more people per bathroom ~ lower rental income). Additionally, there is a strong direct relationship between persons per bathroom and vacancy (more persons per bathroom ~ more vacancy)
8. What do you think about community houses like fraternities and sororities?
 - a. We have only had much experience managing Fraternities. These are historically harder to maintain because of the abuse of the residents. They can be profitable for the owners though, and tend to exclude the property from redevelopment opportunities because of the income of the fraternity.
9. Has your company ever managed some other type of community houses?

- a. We manage 3 large houses for Christian groups that choose to use the house for ministry. There was no property abuse as appose to fraternities. One concern of the Christian groups is to have cheapest available housing option closer to campus. Tenants take good care of the house.

10. What are common problems with managing apartment buildings?

- a. Single family houses
 - i. Issues with vacancy or large maintenance costs can wipe out the profit for a full year or more.
- b. Apartments
 - i. Noisy neighbors, keeping property clean and respectable. In student housing, parties, litter, damage due to student party behavior.

11. Which apartments are easier to lease?

- a. Apartments with greater amenities (more bathrooms, nicer features, larger square footage), that are close to campus

12. Why property owners don't want to demolish their old buildings and build new projects?

- a. Even though the property may look junky, if the income is substantial, it may not make economic sense to demolish for redevelopment. A value based on income must be established for the existing building, and when it will be demolished this value should be ascribed to the cost of land for the new project. In many cases, the high cost of land makes redevelopment not feasible.

13. Would you be interested to build a property using alternative construction materials (shipping containers)?

i. I would be highly skeptical

b. What would you be concerned about (most to least)?

i. Cost (first, always is cost); steel work requires union steel workers and erectors-two very expensive trades compared to residential construction. Other trades may struggle as this type of construction would be unconventional.

ii. Aesthetics and Architectural creativity would be limited

iii. How to insulate? (Thermal and acoustic insulation)

iv. How to maintain?

v. Would this be a type of construction that would be "timeless" and would last many years?

Interview #2 (January 30, 2015)

Interviewer: Tofiq Mammadov - Graduate student at Department of Technology in Illinois State University

Interviewee: Byron Stoller -Manager of Maintenance Department, Young America Realty, Inc. since 1976.

1. What is the current market price of square foot of construction?
 - a. approximately \$125
2. What types of insulation are most popular in residential construction?
 - i. Most expensive, but the best R value per inch: spray foam
 - ii. Less expensive, but lower R value per inch: cellulose
 - iii. Cheapest and lowest R value per inch: fiberglass
 - a. Can we insulate our buildings from the outside?
 - iv. Yes, but in the modern world it is not common. If there is outside insulation then it should not exceed 2 inch thickness, otherwise it is hard to finish.
 - b. How to finish outside insulation?
 - v. Vinyl siding would be considered the cheapest
 - c. How to insulate from the inside if the construction is made out of shipping containers?
 - vi. The interior finishing would be the greatest concern. As long as there is something that allows installing drywalls then any type of insulation can be used.
3. How to install drywalls without framing

- i. As long as it is possible to insert screws into steel walls of a shipping container, there should be no problems with drywalls installation.

Interview #3 (May 6, 2015)

Interviewer: Tofiq Mammadov - Graduate student at Department of Technology in Illinois State University

Interviewee: Bob Lukowski - Rental Coordinator at Great Lakes Kwik Space, since 2014.

1. Price of 40' high cube shipping container approximately \$2 200 per unit
2. Price of delivery approximately \$350 per unit

APPENDIX C
CASE STUDIES

Case study #1: The Lodge on Willow

1. Location: 214 W. Willow, Normal IL 61761
2. Purpose: Student Housing (Residential only, no commercial)
3. Envelope materials: Wood framing with wood exterior sheeting, moisture barrier, and mostly brick and stone veneer. Small amount of wood siding. Also small amount of vinyl siding.
4. Residence is managed by: Young America Realty, Inc.
5. Do you think that this residence affects student's studying performance?
 - i. There may be some benefit derived from the clubhouse, which has study tables, computers, and printer. However, this may be offset by the distraction a pool provides as an alternative to studying.
6. Date of the beginning of construction: May, 2011
7. Date of the beginning of exploitation: June, 2012
8. Number of floors (including ground level):3
9. Number of apartments: 79
10. Numerical data
 - i. Section A:
 1. Total cost of the building (not including price of the lot): \$13.4 Million

2. Total square footage of the building (ft²): 160,000
 3. Share of the building allocated for apartments (ft²): 150,000
 4. Total number of beds: 307
- ii. Section B:
1. Construction cost (subtract price of the lot) per bed:\$43,650
 2. Construction cost (subtract price of the lot) per ft²:\$84
11. Fellowship hall: Yes, in Clubhouse, 4500 ft²;
12. Studying rooms: Yes, in clubhouse
13. Other features:
- i. Pool, Hot tub, Clubhouse, conference room, Wi-Fi at pool/clubhouse, computers and printer provided, grill center, and fire pit.
14. Average annual electrical expenses in US dollars: \$120,000
15. If possible, please attach some interior and exterior pictures of the residence to the email.
- i. <http://www.thelodgeonwillow.com>
16. Feel free to make any advices for similar building design:
- i. This property turned out very well. I'm not sure I'd change much about it. We would love to have additional land to build a second Lodge!

Questions are answered by: Andy Netzer, General Manager & Managing Broker of
Young America Realty

Date: March 11, 2015

Case study #2: Covington Apartments

1. Location: 102 W. Cherry, Normal IL 61761
2. Purpose: Student Housing (Residential only, no commercial)
3. Envelope materials: Wood framing and exterior sheeting with moisture barrier. Brick veneer.
4. Residence is managed by: Young America Realty, Inc.
5. Do you think that this residence affects student's studying performance?
 - ii. I do not think the quality of housing affects the students' ability to study effectively.
6. Date of the beginning of construction: October, 2012
7. Date of the beginning of exploitation: August, 2013
8. Number of floors (including ground level): 5
9. Number of apartments: 16
10. Numerical data
 - iii. Section A:
 1. Total cost of the building (not including price of the lot): \$3.09 Million
 2. Total square footage of the building (ft²): 32,000
 3. Share of the building allocated for apartments (ft²): 26,500
 4. Total number of beds: 56
 - iv. Section B:
 1. Construction cost (subtract price of the lot) per bed: \$55,200
 2. Construction cost (subtract price of the lot) per ft²: \$96.56
11. Fellowship hall: No

12. Studying rooms: No

13. Other features:

v. Covered parking

14. Average annual electrical expenses in US dollars: \$23,000

15. If possible, please attach some interior and exterior pictures of the residence to the email.

vi. <http://yarealty.com/student/apartments/bedrooms/3/property/untitled-amd-item-27>

16. Feel free to make any advices for similar building design:

i. Cost was significantly high. I would like to find a way to avoid having to create a non-combustible barrier between the parking level and the upper levels. This code requirement costs significantly.

Questions are answered by: Andy Netzer, General Manager & Managing Broker of Young America Realty

Date: March 11, 2015

Case study #3: Crosswalk Commons

1. Location: 925 Hilltop Drive, West Lafayette, IN 47906
2. Purpose: International learning and living community
3. Envelope materials: Wood frame with Stone masonry/aluminum metal siding
4. Residence is managed by: Crosswalk Project, Inc.
5. Do you think that this residence affects student's studying performance?
 - i. We seek to provide a quiet community-oriented environment which contributes to the success of our residents.
6. Date of the beginning of construction: September 2012
7. Date of the beginning of exploitation: August 2013
8. Number of floors (including ground level): 4
9. Number of apartments: 32
10. Numerical data
 - i. Section A:
 1. Total cost of the building (not including price of the lot): \$5.57 Million
 2. Total square footage of the building (ft²): 44,000
 3. Share of the building allocated for apartments (ft²): 31,000
 4. Total number of beds: 120
 - ii. Section B:
 5. Construction cost (subtract price of the lot) per bed: \$46,417
 6. Construction cost (subtract price of the lot) per ft²: \$126.6
11. Fellowship hall: Yes
12. Studying rooms: Yes

13. Other features:

- i. Ping pong table, fireplace, community kitchen area, learning center/theater room.

14. Average annual electrical expenses in US dollars: \$45,000

15. If possible, please attach some interior and exterior pictures of the residence to the email.

<http://www.crosswalkcommons.com/gallery/>

16. Feel free to make any advices for similar building design:

- ii. Instead of two larger study rooms, I would include smaller study rooms for individual use. Floors 2, 3 and 4 at Crosswalk have an open lounge/study area at the end of each hall...if I had an opportunity to redesign, these areas would be smaller.

Questions are answered by: Paul Briggs, Secretary/Treasurer, Crosswalk Project, Inc.

Date: March 11, 2015.

APPENDIX D

RESIDENCE BUDGET ESTIMATE

Table D1. *Foundation Cost Estimate.*

Item	Amount	RS Means Data line number	Unit	Cost per unit including O&P	Cost
Pile Cap-1 Pile: 39"x39"x35"	2156.7	03 30 53.40.5900	Cubic Foot	\$12.04	\$25,960
Pile-Steel Pipe: 16" Diameter	1400.0	31 62 23.13.3800	Foot	\$60.50	\$84,700
Excavation	40480.0	31 23 16.46.5200	Cubic Foot	\$0.11	\$4,588
Pile driving set up	1.0	31 06 60.14.1100	Each	\$14,700.00	\$14,700
Total					\$129,948
O&P - Overhead and Profit					

Table D2. Shipping Containers Superstructure Cost Estimate.

Type	Amount	Required Steel cutting in FT	Cost of modification	Cost of Delivered Containers	Total Cost
40' HC for two BR	24	78	\$3,912	\$61,200	\$65,112
40' HC for BR, Hall and Bath	24	132	\$6,621	\$61,200	\$67,821
40' HC for BR and Kitchen	24	108	\$5,417	\$61,200	\$66,617
40' HC for Entrance	2	154	\$644	\$5,100	\$5,744
40' HC for Fellowship Hall	2	168	\$702	\$5,100	\$5,802
40' HC for Studying Area	8	150	\$2,508	\$20,400	\$22,908
Twist Locks	280				\$14,000
Total	84		\$19,805	\$214,200	\$248,005

HC - high cube | BR - bed room
 Cost of 1 delivered 40' HC container: \$ 2 550 (includes delivery charge of \$350 per container, from Chicago, IL to Normal, IL.)
 RS means line number for steel cutting: 05 05 21.10.0050 (Cost per FT: \$2.09).
 Based on online search average price of twist locks is assumed to be \$50 per unit.
 Cost of bolts and nuts is not included, 5% of other expenses is covering this type of costs.

Table D3. Conventional Superstructure Cost Estimate.						
Type	RS Means Data line number	Description	Units	Cost per unit including O&P	Amount	Cost per element
Reinforced Concrete Columns	03 30 53.40.1100	4000 psi, 12" diameter, less than 2% reinforcement	CY	\$1,050	16.71	\$17,543
Reinforced Concrete Columns	03 30 53.40.1200	4000 psi, 16" diameter, less than 2% reinforcement	CY	\$785	11.88	\$9,327
Reinforced Concrete Columns	03 30 53.40.1300	4000 psi, 20" diameter, less than 2% reinforcement	CY	\$675	18.56	\$12,531
Reinforced Concrete Cast in place	03 30 53.40.0500	Beams 3500 psi, 5 kip/LF, span 25'	CY	\$1,175	8.82	\$10,362
Reinforced Concrete Cast in place	03 30 53.40.0300	Beams 3500 psi, 5 kip/LF, span 10'	CY	\$1,325	6.35	\$8,415
Reinforced Concrete Precast	03 41 33.10.1400	beams, 30' span, I changed the units	LF	\$184	126.50	\$23,297
Reinforced Concrete Precast	03 41 33.10.0050	joists, 8" deep, 16' span	LF	\$50	719.05	\$35,593
Reinforced Concrete Precast	03 41 33.10.0015	joists, 6" deep, 12' span	LF	\$33	572.88	\$18,618
Wood Framing	06 11 10.10.3585	I-Beams [2x14]	MBF	\$1,700	0.47	\$796
Wood Framing	06 11 10.18.2745	Dimensional lumber [2x12]	MBF	\$1,425	2.55	\$3,633
Total						\$140,115
CY - Cubic yard LF - Linear foot MBF - Thousand board feet						
Note: Wood framing is used to design structural support for the flooring of the fellowship hall and the roof that is above it.						

Table D4. Stairwells Cost Estimate.

Type	RS Means Data line number	Description	Units	Amount	Cost per unit including O&P	Cost per element
Stairs and railings	03 30 53.40.6800	Stairs: 3500 psi, 3'-6" wide	FT	187	\$46.50	\$8,696
Stairs and railings	05 52 13.50.0500	Railing: Handrail - Pipe on stairs	FT	205	\$46.50	\$9,513
Stairs and railings	05 52 13.50.0930	Railing: Handrail - Pipe on walls	FT	198	\$31.00	\$6,138
Floors and landings	03 31 13.25.0125	Concrete hand mix for small quantities	CF	144	\$8.25	\$1,187
Floors and landings	05 31 13.50.5200	2" deep metal decking, 22 ga.	SF	341	\$2.85	\$972
Floors and landings	03 30 53.40.7000	Stair landing free standing	SF	231	\$21.50	\$4,967
Walls	03 30 53.40.4200	Concrete 3000 psi, Wall free standing	CF	112	\$18.15	\$2,032
Walls	04 21 13.14.0140	Thin brick veneer, super emperor, 8"x3/4"x16" metal panel support system included	SF	299	\$15.75	\$4,709
Walls	06 16 36.10.0705	Plywood sheathing, 5/8", pneumatic nailed	SF	299	\$1.69	\$505
Walls	09 21 16.33.0500.2	Partition wall, incl. 2x4 wood std., tape and finish	SF	4,895	\$1.72	\$8,419
Walls	09 29 10.30.0450	Gypsum board, fire resistant, taped and finished (level 4 finish)	SF	18,675	\$1.58	\$29,507
Doors and windows	08 13 13.13.0060	Standard hollow metal doors	EA	11	\$450.00	\$4,950
Doors and windows	08 53 13.30.0310	Window, Fixed, vinyl, 3'x4'	EA	8	\$288.00	\$2,304
Total						\$83,898
FT - Feet CF - Cubic foot SF - Square foot EA - Each						
Note: 09 21 16.33.0500.2 Line number was generated manually, price of drywall finishes was subtracted, 09 29 10.30.0450 line number was used as a base.						

Table D5. Common Shared Areas and Elevator Cost Estimates.

Item	Fellowship Hall	Gym	Studying rooms	Corridors	Elevator	Total
Doors & Windows	\$6,512	\$5,146	\$22,208	\$2,240	\$0	\$36,106
Ceilings	\$0	\$0	\$9,042	\$15,718	\$0	\$24,760
Walls	\$21,540	\$26,214	\$20,397	\$2,032	\$19,900	\$90,083
Floors	\$18,238	\$24,590	\$9,701	\$32,099	\$0	\$84,629
Plumbing, HVAC, Electrical	\$40,385	\$31,358	\$22,467	\$7,502	\$0	\$101,712
Furniture & Equipment	\$10,700	\$36,200	\$22,992	\$0	\$59,500	\$129,392
Total	\$97,375	\$123,508	\$106,807	\$59,592	\$79,400	\$466,682

Table D6. Common Shared Areas Detailed Cost Estimates.

Item	RS Means Data line number	Description	Units	Amount	Cost per unit including O&P	Cost per element
Doors & Windows	08 14 16.09.3340	Flush Doors, M.D. overlay over hardboard 3'x6'-8"	EA	44	\$224.00	\$9,856
Doors & Windows	08 16 13.10.0040.1	Entrance Door Fiberglass door, 3'x6'-8" + side lights, 1' wide 6'-8" high	EA	2	\$636.00	\$1,272
Doors & Windows	08 32 13.10.4080	Doors Sliding Aluminum, anodized, temp glass, 6'-8"x6'-0"	EA	2	\$785.00	\$1,570
Doors & Windows	08 53 13.30.0310	Window, vinyl double hung, Premium double insulated, 3'-0"x4'-0"	EA	16	\$288.00	\$4,608

Note: Line 08 16 13.10.0040.1 is a combination of two lines in RS means data base: 08 16 13.10.0040 and 08 16 13.10.0150
Continued

Table D6 Continued						
Item	RS Means Data line number	Description	Units	Amount	Cost per unit including O&P	Cost per element
Doors & Windows	08 53 13.30.0380	Window, vinyl double hung, Premium double insulated, 3'-6"x6'-0"	EA	40	\$470.00	\$18,800
Ceilings	09 21 16.33.0500.1	Partition wall, 1 side 1/2" drywall, incl. 2x4 wood std., tape and finish	SF	7503	\$3.30	\$24,760
Walls	09 21 16.33.0500	Partition wall, 2 sides 1/2" drywall, incl. 2x4 wood std., tape and finish.	SF	10835	\$4.88	\$52,875
Walls	03 45 13.50.0650	Precast Concrete wall, high-rise, 10'x20' 6" thick	SF	400	\$33.00	\$13,200
Walls	09 21 16.33.0500.1	Partition wall, 1 side 1/2" drywall, incl. 2x4 wood std., tape and finish	SF	3664	\$3.30	\$12,091
Walls	09 29 10.30.0450	Gypsum board, fire resistant, taped and finished (level 4 finish)	SF	4904	\$1.58	\$7,748
Walls	06 16 23.10.0205	Plywood sheathing 3/4" thick, pneumatic nailed	SF	531	\$1.70	\$903
Walls	07 21 16.20.1320	Mineral wool batts 3 1/2 in, R15	SF	3234	\$1.01	\$3,266
Floors	09 68 16.10.3670	Sheet carpet, Olefin, 26 oz., medium traffic	SF	10,440	\$3.06	\$31,900
Floors	32 18 23.33.0102	Latex rubber system, 1/2"	SF	2,399	\$6.22	\$14,927
Floors	03 05 13.25.0950	Sand, washed for concrete	CF	1,040	\$0.98	\$1,021
Floors	03 30 53.40.4760	Slab on grade (3500psi) finished, not including forms	SF	3,120	\$2.77	\$8,642
Floors	06 16 23.10.0205	Plywood sheathing 3/4" thick, pneumatic nailed	SF	6,523	\$1.70	\$11,089
Note: Line 09 21 16.33.0500.1 was developed based on subtraction of 1 side drywall cost and used for both walls and Ceilings						
Continued						

Table D6 Continued

Item	RS Means Data line number	Description	Units	Amount	Cost per unit including O&P	Cost per element
Floors	06 11 10.18.2725	Joist framing 2x10, pneumatic nailed	CF	451	\$17.10	\$7,712
Floors	09 68 10.10.9000	Sponge rubber pad minimum	SF	10,440	\$0.89	\$9,338
Plumbing, HVAC, Electrical	50 17 00 2720	Plumbing Apartments Low rise (1 to 3) Min	SF	2016	\$5.70	\$11,491
Plumbing, HVAC, Electrical	22 41 13.40.1102	Water closet economy, floor mounted	EA	4	\$380.00	\$1,520
Plumbing, HVAC, Electrical	22 41 16.10.1000	Lavatories, Sink, Cultured marble	EA	4	\$390.00	\$1,560
Plumbing, HVAC, Electrical	50 17 00 2770	HVAC Apartments Low rise (1 to 3) Min	SF	8688	\$3.63	\$31,537
Plumbing, HVAC, Electrical	50 17 00 2900	Electrical Apartments Low rise (1 to 3) Min	SF	8688	\$6.40	\$55,603
Furniture & Equipment	12 21 13.13.0020	Window blinds, metal, horizontal	SF	144	\$6.25	\$900
Furniture & Equipment	Not found	Billiard table	EA	2	\$1,000.00	\$2,000
Furniture & Equipment	Not found	Tennis table	EA	2	\$250.00	\$500
Furniture & Equipment	Not found	L shape sofa	EA	6	\$1,000.00	\$6,000
Furniture & Equipment	Not found	Coffee table	EA	3	\$200.00	\$600
Furniture & Equipment	Not found	Projector	EA	1	\$700.00	\$700

Note: Some of the furniture & equipment costs were derived straight from web sources RS Means (2013) doesn't provide users with Plumbing, HVAC, and Electrical data for Mid-rise buildings. Therefore Low rise square foot data was used.

Continued

Table D6 Continued							
Item	RS Means Data line number	Description	Units	Amount	Cost per unit including O&P	Cost per element	
Furniture & Equipment	12 21 13.13.0020	Window blinds, metal, horizontal	SF	576	\$6.25	\$3,600	
Furniture & Equipment	12 52 23.13.2280	Chair, Task minimum	EA	64	\$178.00	\$11,392	
Furniture & Equipment	Not found	Tables	EA	32	\$250.00	\$8,000	
Furniture & Equipment	12 21 13.13.0020	Window blinds, metal, horizontal	SF	144	\$6.25	\$900	
Furniture & Equipment	11 66 13.10.1340	Treadmill, electronic	EA	4	\$4,075.00	\$16,300	
Furniture & Equipment	11 66 13.10.1280	Rowing machine	EA	2	\$1,925.00	\$3,850	
Furniture & Equipment	11 66 13.10.1200.1	Multi-station gym machine, #2	EA	1	\$2,200.00	\$2,200	
Furniture & Equipment	11 66 13.10.4390	Weight lifting	EA	2	\$1,275.00	\$2,550	
Furniture & Equipment	11 66 13.10.0820	Dumbbell	EA	1	\$620.00	\$620	
Furniture & Equipment	11 66 13.10.1200.2	Multi-station gym machine, #1	EA	1	\$1,100.00	\$1,100	
Furniture & Equipment	11 66 13.10.1200	Multi-station gym machine, #5	EA	1	\$5,500.00	\$5,500	
Note: Cost estimates of 11 66 13.10.1200.1 and 11 66 13.10.1200.2 were derived from 11 66 13.10.1200							
Continued							

Table D6 Continued

Item	RS Means Data line number	Description	Units	Amount	Cost per unit including O&P	Cost per element
Furniture & Equipment	Not found	Leg Extension	EA	4	\$530.00	\$2,120
Furniture & Equipment	11 66 13.10.0020	Abdominal rock	EA	2	\$530.00	\$1,060
Furniture & Equipment	14 21 33.20.7300	Residential elevator, maximum	EA	1	\$59,500.00	\$59,500
Total						\$466,682

Note: Not found item in this case derived from the cost of abdominal rock machine

Table D7. Apartment's Cost Estimate.

Apartment's elements	RS Means Data line number	Description	Units	Amount	Cost per unit including O&P	Cost of element	Cost multiplied by number of apartments
Door & Window	08 14	Interior doors, six panel, hollow core, 2'-6"x6'-8"	EA	2.0	\$137.0	\$274	\$6,576
Door & Window	08 14	Interior bi-fold doors, 4'x6'-8"	EA	4.0	\$215.0	\$860	\$20,640
Door & Window	08 14	Flush Doors, M.D. overlay over hardboard 3'x6'-8"	EA	6.0	\$224.0	\$1,344	\$32,256
Door & Window	08 16	Entrance Door Fiberglass door, 3'x6'-8"	EA	1.0	\$360.0	\$360	\$8,640
Door & Window	08 53	Window, vinyl double hung, Premium double insulated, 3'-6"x6'-0"	EA	4.0	\$470.0	\$1,880	\$45,120
Ceilings	16.33.0500.1	Partition wall, 1/2 drywall 1 side incl. 2x4 wood std., tape and finish	SF	935.0	\$3.3	\$3,086	\$74,052
Walls	06 11	Wall framing Studs 8' high 2x4	CF	5.7	\$33.9	\$193	\$4,638
Walls	16.20.1320	Mineral wool batts 3 1/2 in, R15	SF	662.0	\$1.0	\$669	\$16,047
Walls	07 21	1" Closed cell, spray polyurethane foam, 2 pounds per cubic foot density	SF	662.0	\$1.0	\$629	\$15,094

Note: Line 09 21 16.33.0500.1 was developed based on subtraction of 1 side drywall cost

Continued

Table D7 Continued							
Apartment's elements	RS Means Data line number	Description	Units	Amount	Cost per unit including O&P	Cost of element	Cost multiplied by number of apartments
Walls	09 21 16.33.0500	Partition wall, 1/2 drywall 2 sides incl. 2x4 wood std., tape and finish	SF	662.0	\$4.9	\$3,231	\$77,533
Walls	09 21 16.33.0500.1	Partition wall, 1/2 drywall 1 side incl. 2x4 wood std., tape and finish	SF	662.0	\$3.3	\$2,185	\$52,430
Walls	09 29 10.30.0450	Gypsum board, fire resistant, taped and finished (level 4 finish)	SF	1,496.0	\$1.6	\$2,364	\$56,728
Floors	09 68 16.10.3670	Sheet carpet, Olefin, 26 oz., medium traffic	SF	686.0	\$3.1	\$2,096	\$50,307
Floors	09 65 16.10.8000	Vinyl sheet goods, backed, 0.65" thick, minimum	SF	150.0	\$6.5	\$975	\$23,400
Floors	30 31 13.25.0125	Concrete hand mix for small quantities	CF	5.1	\$8.3	\$42	\$1,004
Floors	09 30 13.10.3255	Floors, glazed, thin set, 6x6, color group 1	SF	140.0	\$7.9	\$1,099	\$26,376
Floors	06 16 23.10.0205	Subflooring, Plywood 3/4" thick, pneumatic nailed	SF	104.0	\$1.7	\$177	\$4,243
Floors	06 11 10.18.2725	Joist framing 2x10, pneumatic nailed	CF	80.2	\$17.1	\$1,371	\$32,902
Floors	09 68 10.10.9000	Sponge rubber pad minimum	SF	686.0	\$0.9	\$614	\$14,726
Continued							

Table D7 Continued							
Apartment's elements	RS Means Data line number	Description	Units	Amount	Cost per unit including O&P	Cost of element	Cost multiplied by number of apartments
Floors	03 35 13.30.0100	Concrete finishing, bull float	SF	104.0	\$0.4	\$38	\$924
Casework	12 32 23.10.4700	Casework, kitchen wall, two doors, 24x30	EA	4.0	\$390.0	\$1,560	\$37,440
Casework	12 32 23.30.8050	Vanity bases, 2 doors, 30x30	EA	2.0	\$460.0	\$920	\$22,080
Casework	12 36 19.10.2900	Maple countertops, solid, laminated, 1 1/2" thick, no splash	LF	11.5	\$102.0	\$1,173	\$28,152
Casework	12 32 23.10.1580	Casework, range or sink base, two doors, 48 wide	EA	1.0	\$520.0	\$520	\$12,480
Plumbing, HVAC, Electrical	22 41 13.40.1102	Water closet economy, floor mounted	EA	2.0	\$380.0	\$760	\$18,240
Plumbing, HVAC, Electrical	22 41 16.10.1000	Lavatories, Sink, Cultured marble	EA	2.0	\$390.0	\$780	\$18,720
Plumbing, HVAC, Electrical	22 41 16.30.2000	Sink, kitchen, counter top style	EA	1.0	\$525.0	\$525	\$12,600
Plumbing, HVAC, Electrical	11 31 33.23.6900	Electrical heater, glass lined, 30 gallon	EA	1.0	\$735.0	\$735	\$17,640

Continued

Table D7 Continued

Apartment's elements	RS Means Data line number	Description	Units	Amount	Cost per unit including O&P	Cost of element	Cost multiplied by number of apartments
Plumbing, HVAC, Electrical	22 41 19.10.2000	Bath, enameled, formed steel, 4'-6" long	EA	1.0	\$760.0	\$760	\$18,240
Plumbing, HVAC, Electrical	22 41 23.20.3000	Shower, fiberglass, 32"x32"	EA	1.0	\$770.0	\$770	\$18,480
Plumbing, HVAC, Electrical	50 17 00 2720	Plumbing Apartments Low rise (1 to 3) Min	SF	1,008	\$5.7	\$5,746	\$137,894
Plumbing, HVAC, Electrical	50 17 00 2900	Electrical Apartments Low rise (1 to 3) Min	SF	1,008	\$6.4	\$6,451	\$154,829
Plumbing, HVAC, Electrical	50 17 00 2770	HVAC Apartments Low rise (1 to 3) Min	SF	1,008	\$3.6	\$3,659	\$87,817
Furniture & Appliances	11 31 13.13.0900	Countertop cooktops, 4burner	EA	1.0	\$425.0	\$425	\$10,200
Furniture & Appliances	11 31 13.13.1250	Microwave oven	EA	1.0	\$291.0	\$291	\$6,984
Furniture & Appliances	11 31 13.23.5500	Refrigeration, no frost 10 C.F.	EA	1.0	\$550.0	\$550	\$13,200

Note: RS Means (2013) doesn't provide users with Plumbing, HVAC, Electrical data for Mid-rise buildings. Therefore Low rise square foot data was used.

Continued

Table D7 Continued

Apartment's elements	RS Means Data line number	Description	Units	Amount	Cost per unit including O&P	Cost of element	Cost multiplied by number of apartments
Furniture & Appliances	11 31	Dishwasher	EA	1.0	\$595.0	\$595	\$14,280
Furniture & Appliances	13.33.2750	Ventilation system 2 speed	EA	1.0	\$320.0	\$320	\$7,680
Furniture & Appliances	11 31	Washer, top-loading	EA	1.0	\$720.0	\$720	\$17,280
Furniture & Appliances	13.53.4150	Electrical dryer, front loading, energy star qualified	EA	1.0	\$750.0	\$750	\$18,000
Furniture & Appliances	11 31	Window blinds, metal, horizontal	SF	78.0	\$6.3	\$488	\$11,700
Furniture & Appliances	23.13.6764	Vinyl horizontal louver blinds 72" x 96"	EA	2.0	\$315.0	\$630	\$15,120
Furniture & Appliances	11 31.23.23.6	Desk wood case, 30"x60"	EA	4.0	\$535.0	\$2,140	\$51,360
Furniture & Appliances	770	Chair, Task minimum	EA	4.0	\$178.0	\$712	\$17,088
Furniture & Appliances	12 21	Twin wood frame bed	EA	4.0	\$99.0	\$396	\$9,504
Furniture & Appliances	13.13.0020	Wood chair	EA	4.0	\$33.0	\$132	\$3,163
Furniture & Appliances	12 21	Wood Table-Rectangular	EA	1.0	\$122.0	\$122	\$2,928
Furniture & Appliances	13.33.0320					\$56,114	\$1,346,736
Furniture & Appliances	12 51						
Furniture & Appliances	16.16.0800						
Furniture & Appliances	12 52						
Furniture & Appliances	23.13.2280						
Furniture & Appliances	Not found						
Furniture & Appliances	Not found						
Furniture & Appliances	Not found						
Total							

Note: Some of the furniture elements weren't found in the RS Means (2013). Cost data for that elements was derived from web sources

Table D8. Exterior Floors Spray Insulation Cost Estimate.

Components	RS Means Data line number	Description	Units	Amount	Cost per unit including O&P	Cost of element
Floor insulation	07 21 29.10.0350	5" Closed cell, spray polyurethane foam, 2 pounds per cubic foot density	SF	4144	\$4.72	\$19,560

Table D9. Roofing Cost Estimate.

Components	RS Means Data line number	Description	Units	Amount	Cost per unit including O&P	Cost of element
Roofing	06 16 23.10.0205	Plywood sheathing	SF	7,997.00	\$1.70	\$13,595
Roofing	07 21 29.10.0320	2" Closed cell, spray polyurethane foam, 2 pounds per cubic foot density	SF	4,898.00	\$1.89	\$9,257
Roofing	06 11 10.18.2705	Joist framing 2x8, pneumatic nailed	CF	384.02	\$16.80	\$6,452
Roofing	07 21 16.10.2150	Blanket insulation, fiberglass, 6-1/4", R19	SF	4,448.38	\$1.47	\$6,539
Roofing	07 53 23.20.3700	EPDM, 45 mils, 0.28 psf., mechanically attached	SF	7,997.00	\$1.61	\$12,875
Roofing	09 29 10.30.0450	Gypsum board, fire resistant, taped and finished (level 4 finish)	SF	3,099.00	\$1.58	\$4,896
Roofing	06 11 10.18.2745	Joist framing 2x12, pneumatic nailed	CF	302.31	\$17.10	\$5,170
Roofing	07 21 16.10.2220	Blanket insulation, fiberglass, 12", R38	SF	2,814.52	\$2.12	\$5,967
Roofing	07 53 23.20.3700	EPDM, 45 mils, 0.28 psf., mechanically attached	SF	1,329.00	\$1.61	\$2,140
Roofing	09 21 16.33.0500.2	Partition wall, 3/4 plywood sheathing 2 side incl. 2x4 wood std.,	SF	1,329.00	\$5.12	\$6,804
Total						\$73,695

Table D10. Siding Cost Estimate.

Components	RS Means Data line number	Description	Units	Amount	Cost per unit including O&P	Cost of element
Siding	04 21 13.14.0140	Thin brick veneer, including metal panel support sys, Super emperor, 8"x3/4"x16"	SF	21481	\$15.75	\$338,326
Siding	04 43 10.50.0100	Lightweight natural stone, veneer, rubble face, sawed back, irregular shapes	SF	3616	\$28.00	\$101,248
Total						\$439,574

APPENDIX E

FINANCIAL ANALYSIS

	A	B	F	J	N	R	V	Z	AD
2	Down payment required 20% (Initial Investment)	-743366.736887308							
3	Annual Revenue	5238456.67757325							
4	Bank Annuity at 6%	-220076.6509041							
5	Annual expenses 36%	-169912.67171445							
6	Energy cost	-31656							
7	Inflation Mean	0.0279							
8	Inflation standard deviation	0.0833							
9	Discount rate	0.0833							
10	Time	28							
11	Year	2014	2018	2022	2026	2030	2034	2038	2042
12	Period	0	4	8	12	16	20	24	28
14	Inflation "t"		$=(1+589)^{t/4}$	$=(1+589)^{t/8}$	$=(1+589)^{t/12}$	$=(1+589)^{t/16}$	$=(1+589)^{t/20}$	$=(1+589)^{t/24}$	$=(1+589)^{t/28}$
15	Discount FACTOR		$=1/(1+589)^{t/4}$	$=1/(1+589)^{t/8}$	$=1/(1+589)^{t/12}$	$=1/(1+589)^{t/16}$	$=1/(1+589)^{t/20}$	$=1/(1+589)^{t/24}$	$=1/(1+589)^{t/28}$
16	Initial Investment and Annual Revenue	$=B2$	$=B3*(1+589)^{t/4}$	$=B3*(1+589)^{t/8}$	$=B3*(1+589)^{t/12}$	$=B3*(1+589)^{t/16}$	$=B3*(1+589)^{t/20}$	$=B3*(1+589)^{t/24}$	$=B3*(1+589)^{t/28}$
17	Bank Expenses		$=B4*(1+589)^{t/4}$	$=B4*(1+589)^{t/8}$	$=B4*(1+589)^{t/12}$	$=B4*(1+589)^{t/16}$	$=B4*(1+589)^{t/20}$	$=B4*(1+589)^{t/24}$	$=B4*(1+589)^{t/28}$
18	Expenses		$=B5*(1+589)^{t/4}$	$=B5*(1+589)^{t/8}$	$=B5*(1+589)^{t/12}$	$=B5*(1+589)^{t/16}$	$=B5*(1+589)^{t/20}$	$=B5*(1+589)^{t/24}$	$=B5*(1+589)^{t/28}$
19	Energy expenses		$=B6*(1+589)^{t/4}$	$=B6*(1+589)^{t/8}$	$=B6*(1+589)^{t/12}$	$=B6*(1+589)^{t/16}$	$=B6*(1+589)^{t/20}$	$=B6*(1+589)^{t/24}$	$=B6*(1+589)^{t/28}$
20	Cash flows	$=SUM(B16:B19)$	$=SUM(F16:F19)$	$=SUM(J16:J19)$	$=SUM(N16:N19)$	$=SUM(R16:R19)$	$=SUM(V16:V19)$	$=SUM(Z16:Z19)$	$=SUM(AD16:AD19)$
21	Discounted CF	$=B20*B15$	$=F20*F15$	$=J20*J15$	$=N20*N15$	$=R20*R15$	$=V20*V15$	$=Z20*Z15$	$=AD20*AD15$
22	Cumulative Discounted CF	$=B21$	$=B22+B21$	$=B23+B22$	$=B24+B23$	$=B25+B24$	$=B26+B25$	$=B27+B26$	$=B28+B27$
23	NPV	$=B22$							
24	IRR	$=IRR(B21:AD21)$							
25	PI	$=NPV(IRR(C20:AD20)/B16$							
26	DPM	$=INTERCEPT(B13:AD13,B32:AD32)$							

Figure E1. Excel Formulas Used to Extrapolate Cash Flows.
 Note: Numbers used in the current sample form are related to the alternative residence with assumption that 11% ROI is required.

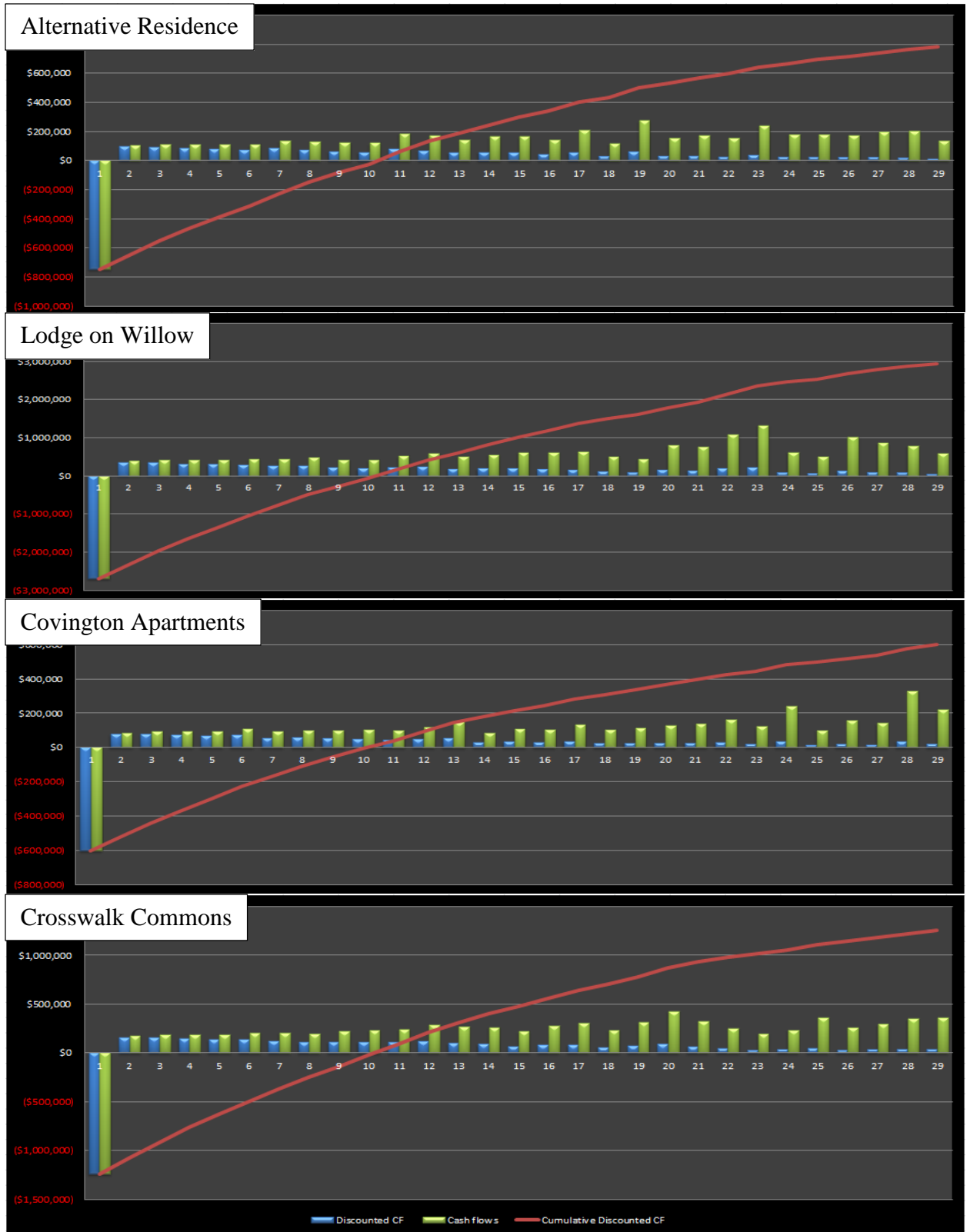

Figure E2. Cash Flow Projections under the Assumption of no Market Competition.
 Note: Flexible rental price, ROI-11%.

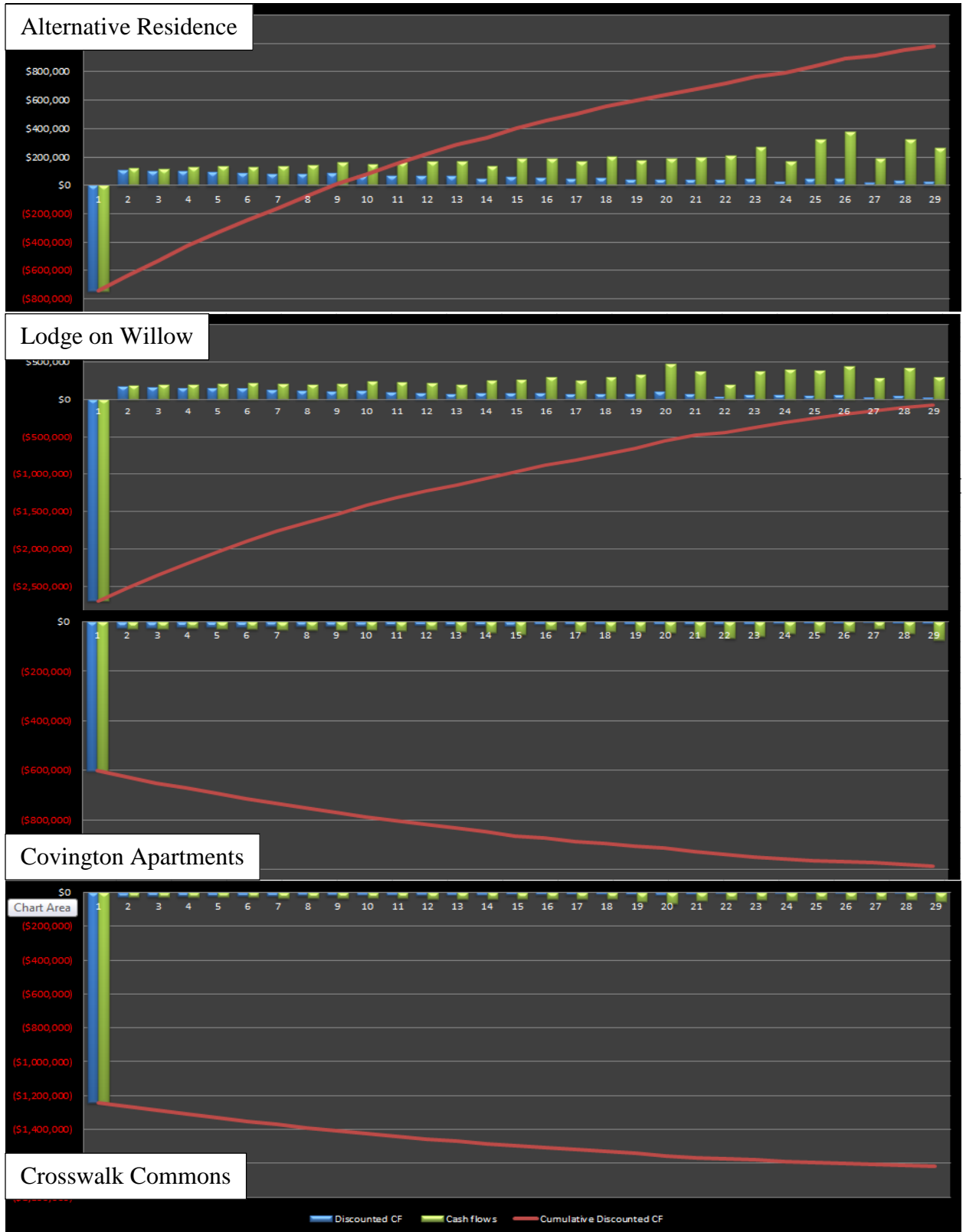

Figure E3. Cash Flow Projections under the Assumption of the Competitive Market.
 Note: Rental price \$469 for all projects, ROI - 12%.

Figure E3 shows a graphical representation of the cash flow projections. The analysis of those graphs reveals that under specified market conditions, even the Lodge on Willow is not able to break even for the discounted payback curve. It means that investors will not be able to get their money back in 28 years. The graphical analysis of the Covington Apartments and the Crosswalk Commons reveals that those projects will not be able to generate positive revenue.

APPENDIX F
DISTRIBUTIONS OF NPV GENERATED THROUGH
MONTE CARLO SIMULATION

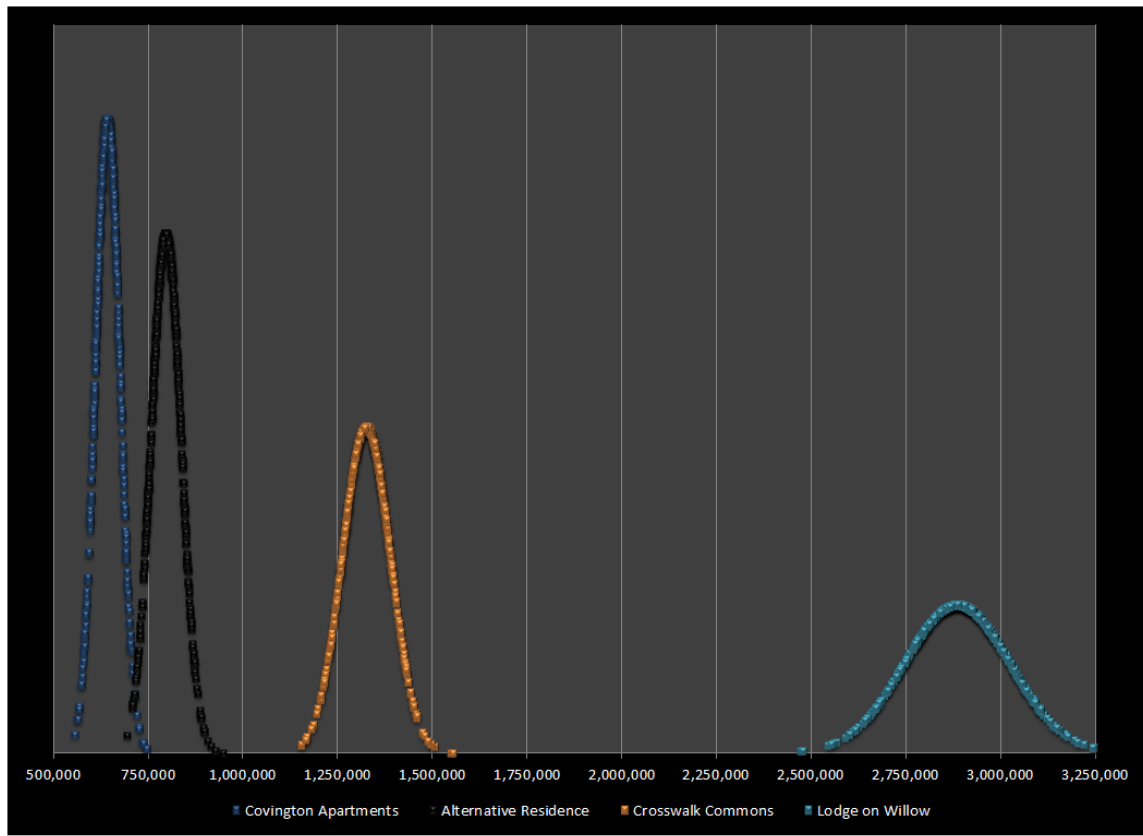

Figure F1. NPV Distributions at 11%.

Note: The current simulation was conducted under the assumptions of 11% ROI and every residence operate under desired rental prices.

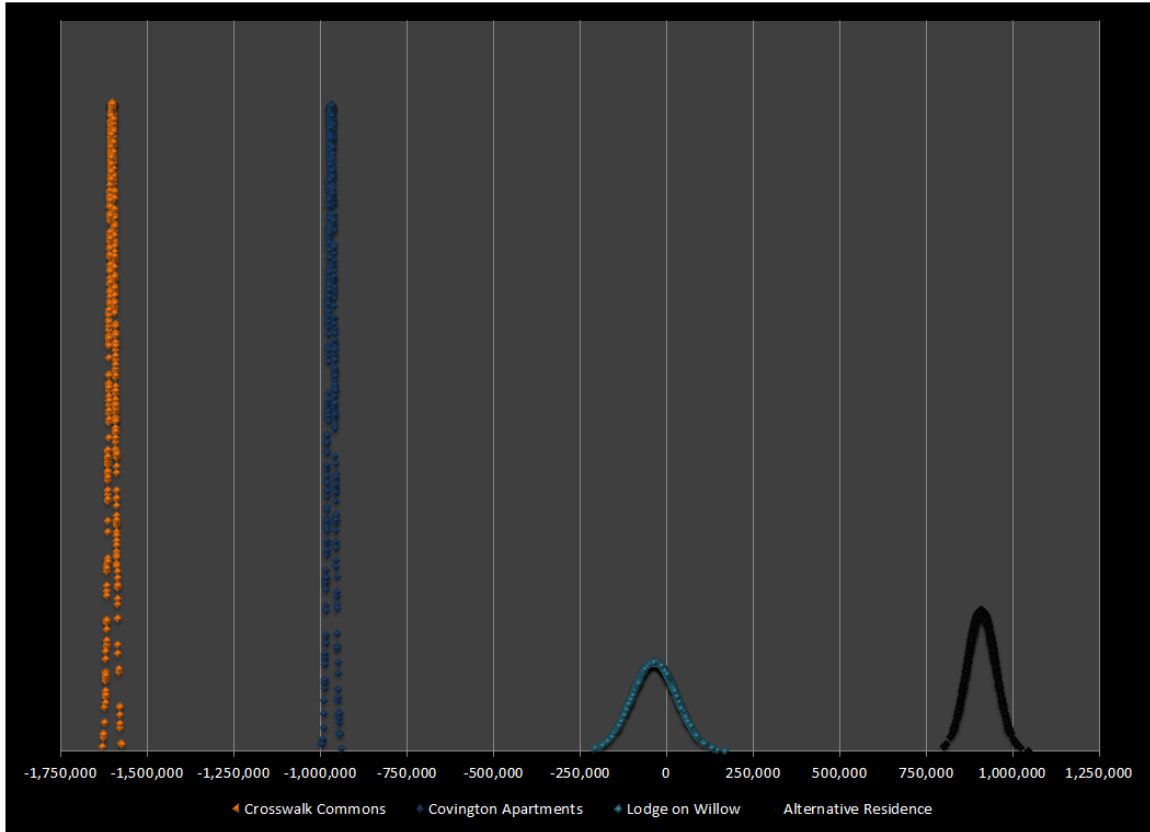

Figure F2. *NPV Distributions at 12%.*

Note: The current simulation was conducted under the assumptions of 12% ROI and every residence compete for lower rental prices.

APPENDIX G
CONSTRUCTION AND INSULATION
MATERIALS R VALUES

Material	N/A Thickness R Value	R/Inch hr·ft ² ·°F/Btu	R/Thickness hr·ft ² ·°F/Btu
Outside Air Film	0.17		
Inside Air Film	0.68		
Steel			0.61
Spray foam (Polyurethane)		6.25	
High-density Fiberglass		4.30	
Wood stud		1.25	
Drywall		0.90	
EPDM		1.76	
Plywood		1.26	

Professionals Corner (n.d.)